

BILSTEIN

MOTORSPORTS SHOCK ABSORBERS

Oval Track Valving Manual

FOR "TAKE-APART" SHOCKS



Aftermarket & Motorsports Headquarters
14102 Stowe Drive
Poway, CA 92064-7147
858/386-5900, Fax: 858/386-5901
www.bilstein.com

Eastern Aftermarket & Motorsports
293 Timber Road
 Mooresville, NC 28115-7868
704/663-7563
Fax: 704/663-7585



INTRODUCTION

Bilstein is pleased to offer this **Revalving Service Procedures Manual** to teams running our serviceable Bilstein gas pressure shock absorbers for oval track racing.

This manual has been prepared to assist teams in achieving the proper Bilstein shock valvings to fit the requirements of their specific type of car and racing series. By simply following the procedures in this manual, Bilstein racing shock revalving may be performed at the track during test sessions or in pre-race practice.

This manual contains the step-by-step procedures on how to disassemble, revalve and reassemble serviceable Bilstein racing shock as well as identifying and describing the various component parts within Bilstein shocks. This manual has been designed to coincide with the Bilstein Motorsports Catalog for oval track racing which contains our recommended compression and rebound shock valvings for the various tracks and racing surfaces. After a valving has been determined, this manual shows you how to build the desired internal valve stack for these specifications.

Because Bilstein shocks are gas pressurized, it is imperative that the step-by-step instructions be followed exactly to prevent any risk of injury during pressurizing.

If you have any questions regarding the procedures outlined in this manual contact your Bilstein area field representative or call the Bilstein Motorsports Services Department at 800/537-1085.

We appreciate your good judgement in running the proven reliability and fade free performance of Bilstein shocks, and we wish you the best of luck during the season.

Bilstein Motorsports

For Complete Information Contact:

Aftermarket & Motorsports Headquarters

14102 Stowe Drive
Poway, CA 92064-7147
858/386-5900

Eastern Aftermarket & Motorsports

293 Timber Road
Mooresville, NC 28115-7868
704/663-7563



TABLE OF CONTENTS

Page 1	Introduction
Page 2	Table Of Contents
Pages 3-10	Component Descriptions
Pages 11-15	Circlip Type - Disassembly, Revalving, Assembly Procedures
Pages 16-18	Threaded Rod Guide Type - Disassembly, Revalving, Assembly Procedures
Pages 19-21	Large Nitrogen Compartment Series - Disassembly, Revalving, Assembly Procedures
Pages 22-24	Rebuildable-Revalvable Series - Disassembly, Revalving, Assembly Procedures
Pages 25-27	Econo Aluminum Series (ATAD/ATAL Type) - Disassembly, Revalving, Assembly Procedures
Pages 28-33	Short Track (Linear & Digressive) Valving Specifications
Pages 34-77	GN Revalving Specifications
Pages 78	Oil Volume For Motorsports Shocks

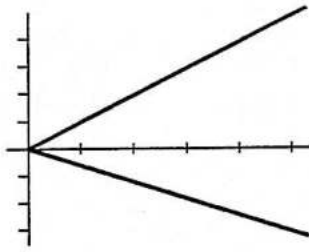

LINEAR

rebound side

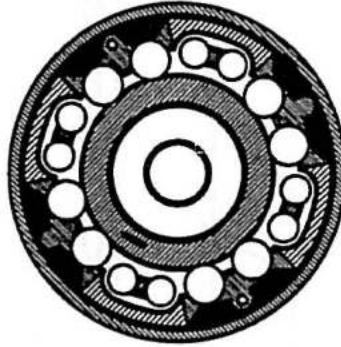

compression side

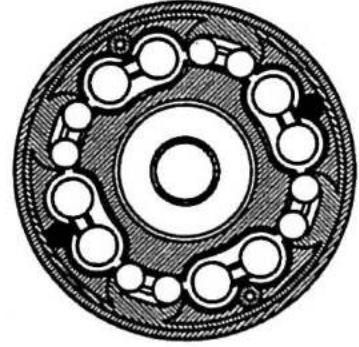

B46-U148T

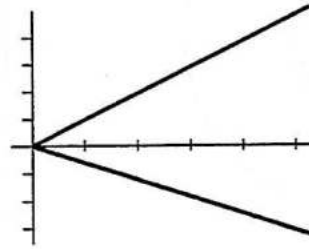

LINEAR

rebound side

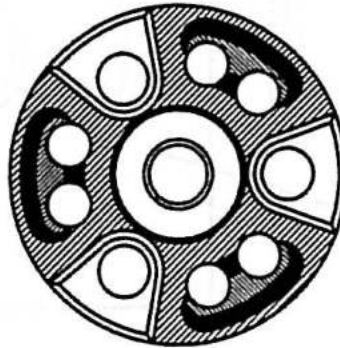

compression side

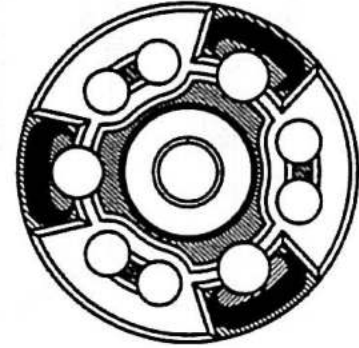

B46-U37T

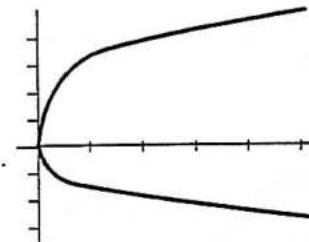

DIGRESSIVE

(both sides identical)



B46-699A

PISTON IDENTIFICATION & ORIENTATION

ROD GUIDE / SEAL ASSEMBLY

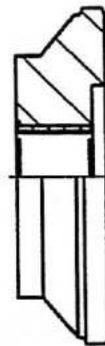
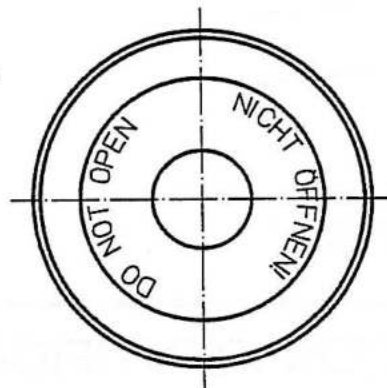
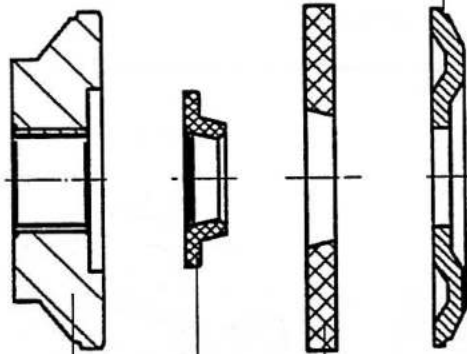

rod guide

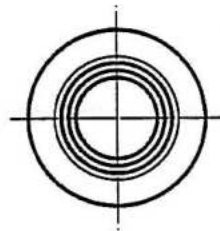

rod seal

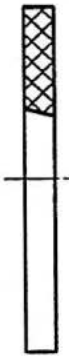
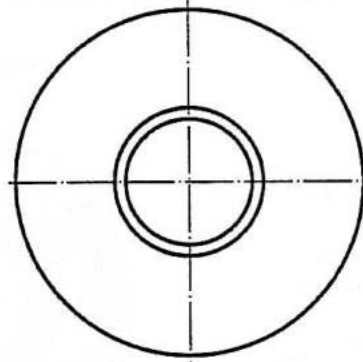

tube seal (outer seal)

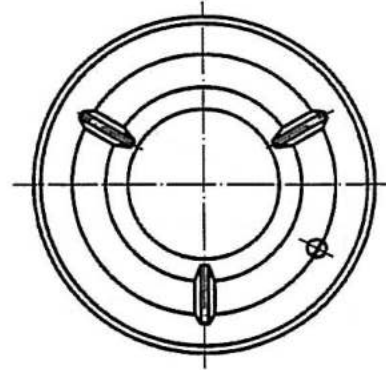

inner plate

ONE-PIECE ROD GUIDE

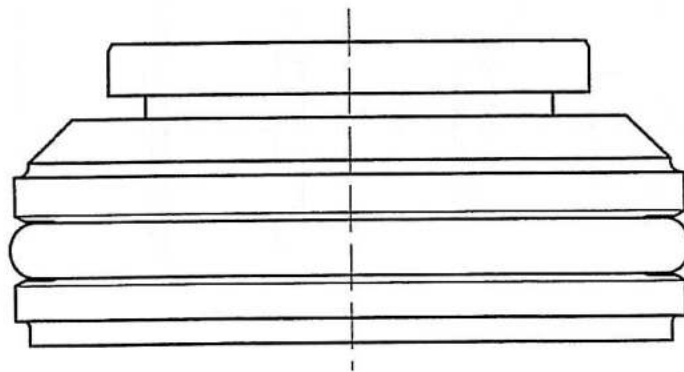
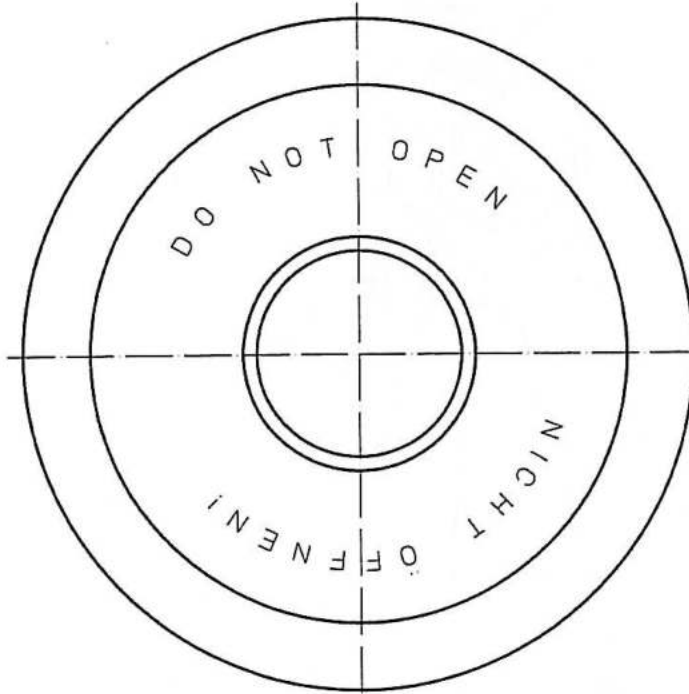

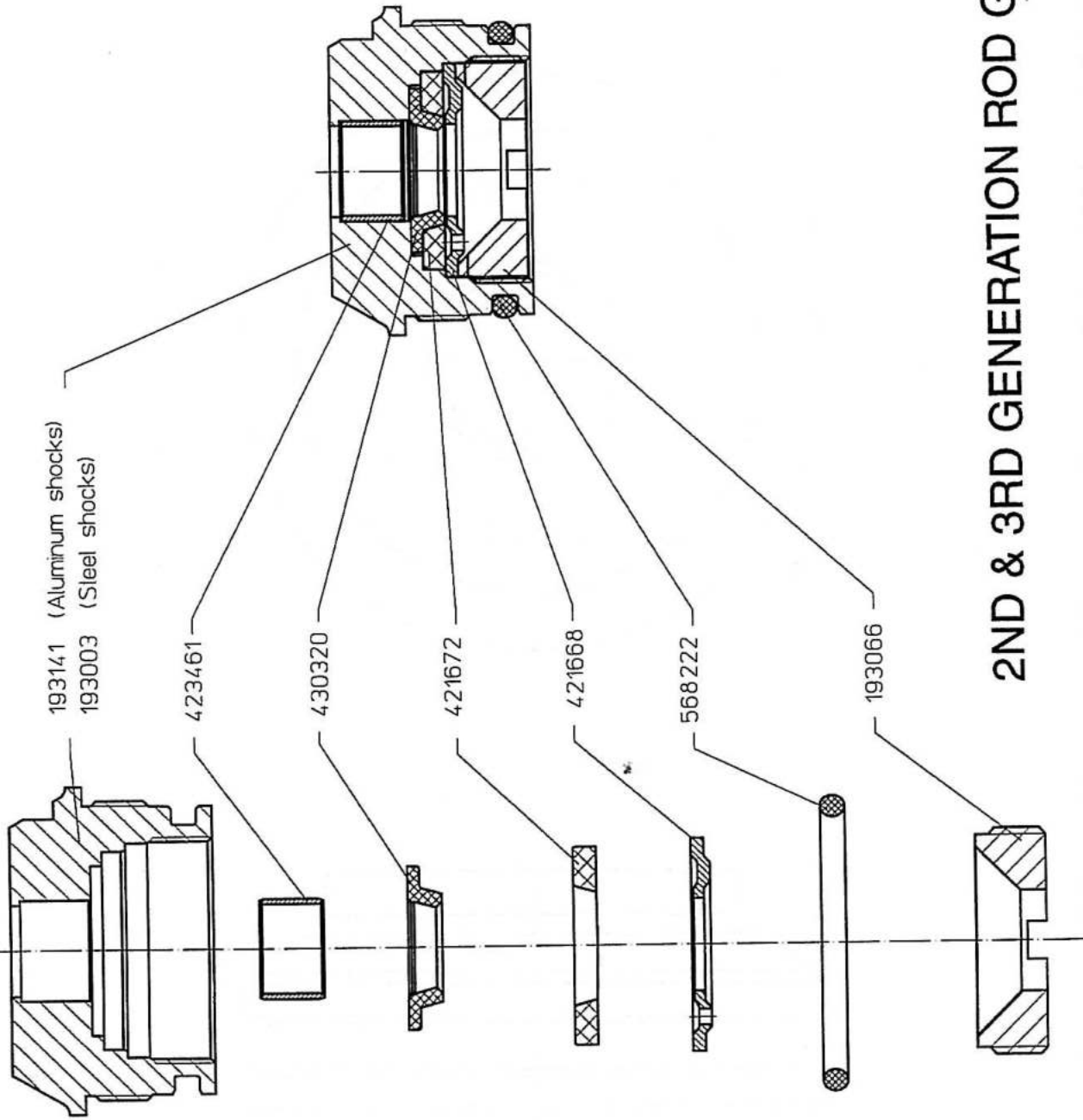

2ND & 3RD GENERATION ROD GUIDE



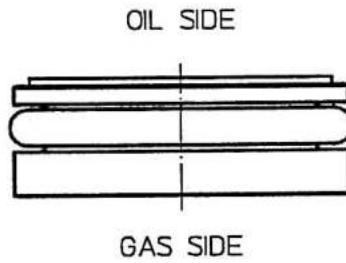
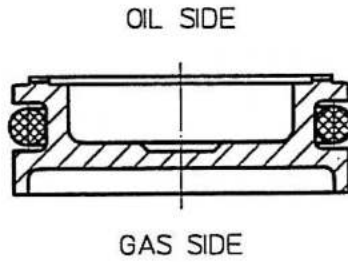

DIVIDING PISTON IDENTIFICATION & ORIENTATION

SUPPORT WASHERS 21x3F & 21x3C

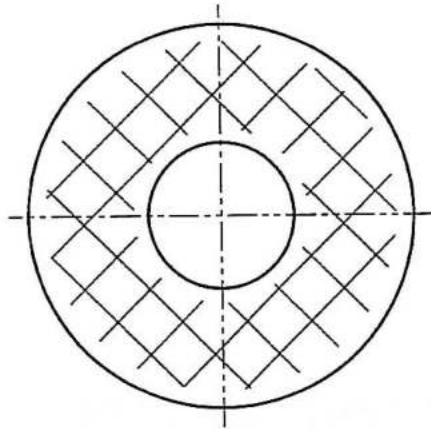

"21x3F"

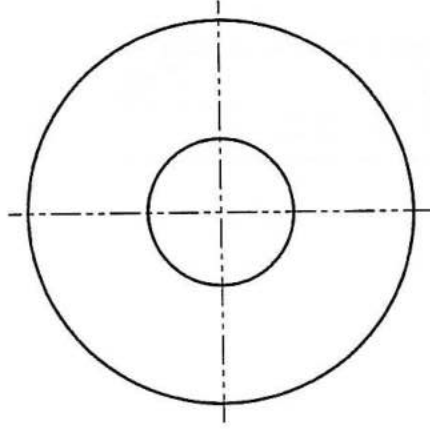

"21x3C"

NOTE: "21x3F" and "21x3C" can be substituted for one another as follows:

To substitute "21x3F" for "21x3C"; increase next disc diameter by 0.5 mm.

To substitute "21x3C" for "21x3F"; decrease next disc diameter by 0.5 mm.

BYPASS ORIFICE PLATES

(46mm standard shocks)

part number	thickness (mm)	bypass area (mm ²)
B46-742A1	0.15	0.9
B46-742B1	0.20	1.2
B46-742C1	0.25	1.5

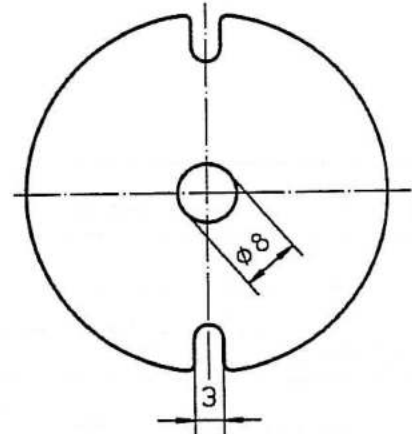

part number	thickness (mm)	bypass area (mm ²)
B46-743A1	0.15	1.8
B46-743B1	0.20	2.4
B46-743C1	0.25	3.0

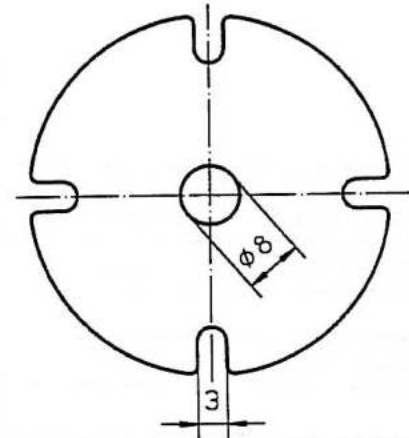

part number	thickness (mm)	bypass area (mm ²)
B46-744A1	0.15	3.6
B46-744B1	0.20	4.8
B46-744C1	0.25	6.0

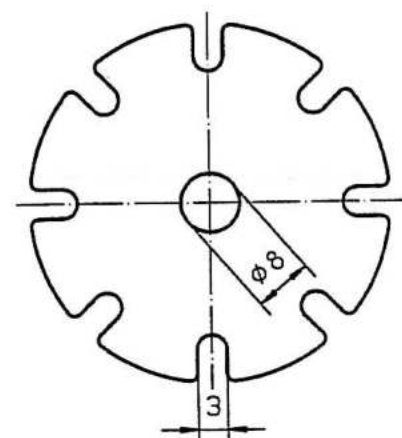

BYPASS ORIFICE PLATES

(46mm adjustable shocks)

part number	thickness (mm)	bypass area (mm ²)
B46-743A2	0.15	1.8
B46-743B2	0.20	2.4
B46-742C2	0.25	3.0

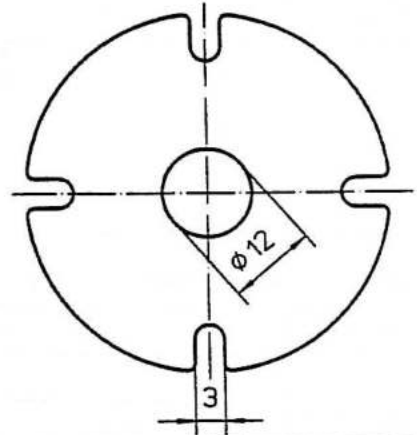

part number	thickness (mm)	bypass area (mm ²)
B46-744A2	0.15	3.6
B46-744B2	0.20	4.8
B46-744C2	0.25	6.0

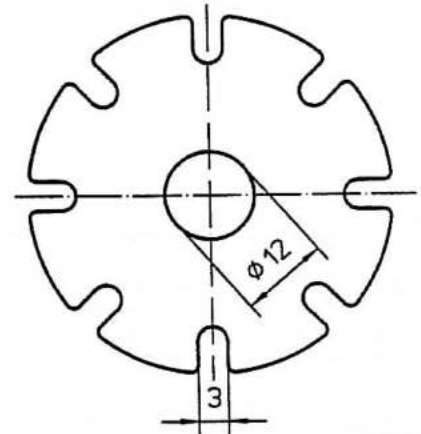

**Disassembly
Revalving
and
Assembly
Procedures**

Circlip Type - *DISASSEMBLY PROCEDURES*

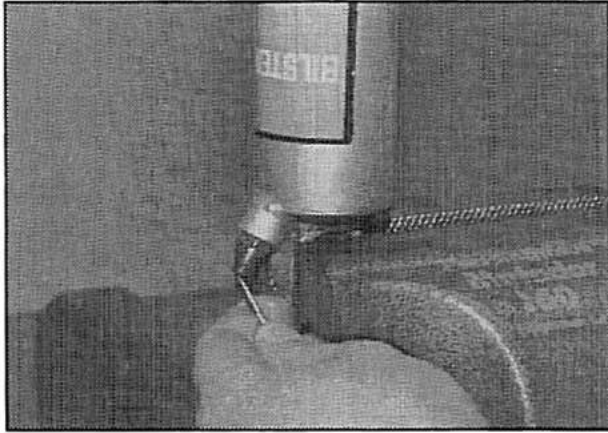

1. Release all gas pressure from the shock through the Schrader valve.

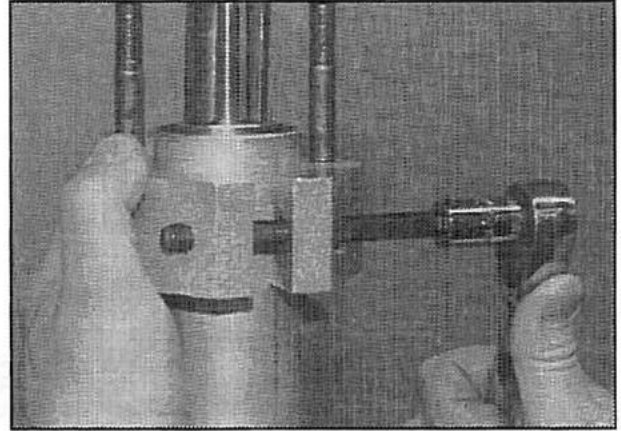

2. Fit the Bilstein clamp tool over the shock body and tighten the clamp bolt.

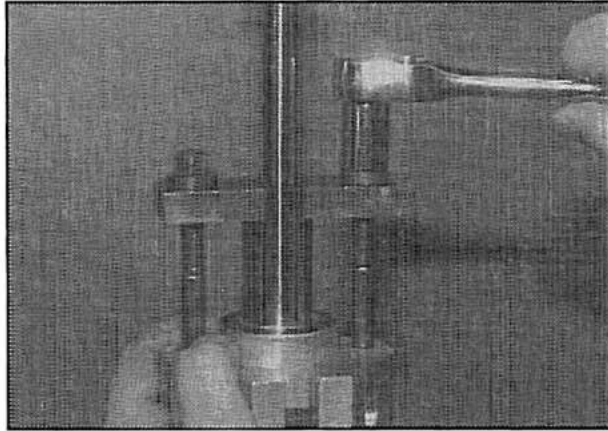

3. Tighten both nuts evenly to compress the rod guide enough to expose the outer snap ring.

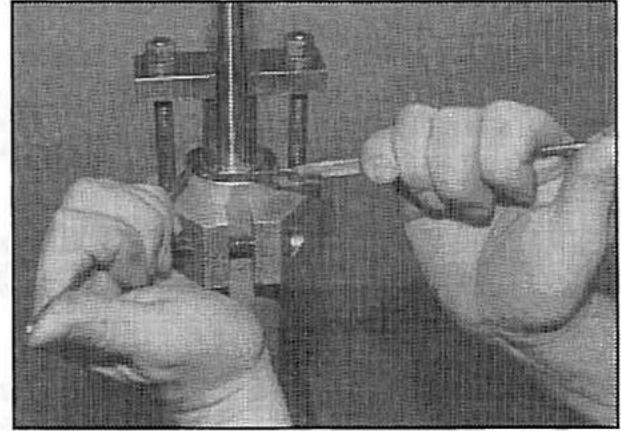

4. Recheck that all gas pressure has been released through the Schrader valve. Then remove the outer snap ring and gradually back off both nuts until there is no tension on the clamp head. Loosen the clamp bolt and remove the clamp tool from the shock.

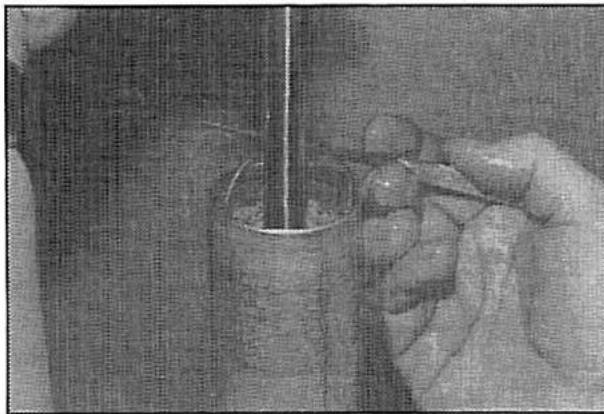

5. Remove the rod guide, rod seal, tube seal and support plate. Then remove the inner snap ring, taking care not to scratch the tube bore.

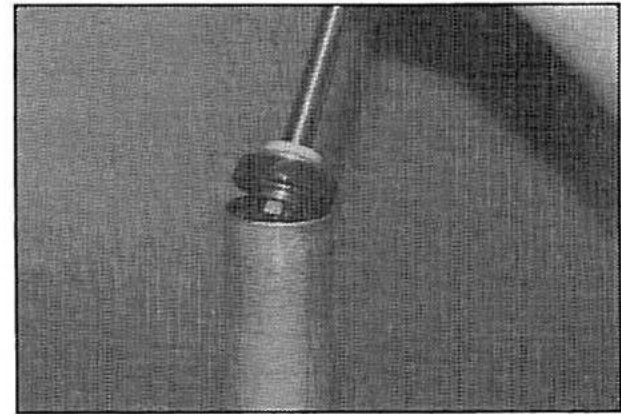

6. Slowly pull the piston rod, with piston and valves upwards, out of the shock body. Pour the fluid into a clean beaker (Part #193020). If needed, discard used fluid and replace with new Bilstein shock oil.

Circlip Type - REVALVING PROCEDURES

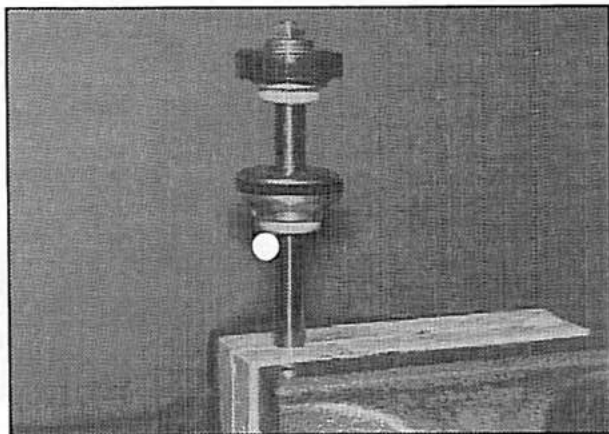

1. Hold piston rod, with piston upwards, tightly in a vise equipped with soft jaws suitable for holding the 14 mm (0.55") diameter piston rod.

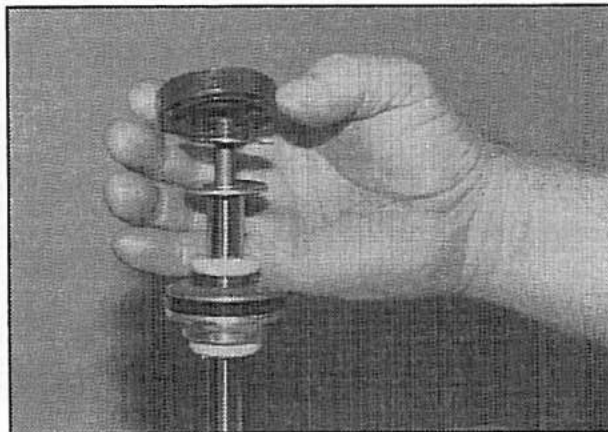

2. Remove and discard the M8 x 1 hex nut. Then remove the piston and discard all valve parts.

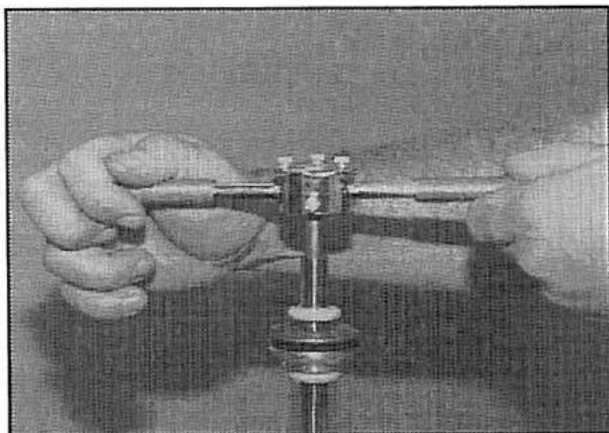

3. Chase the threads on the piston rod using an M8 x 1 die (Part #193050). Remove any metal fragments from the rod tenon.



4. Assemble the new valve components and piston onto the piston rod tenon, referring to the appropriate valving sheet (For example: 480/160D DIGRESSIVE).



5. Install a new hex nut and tighten to specification on valving sheet.

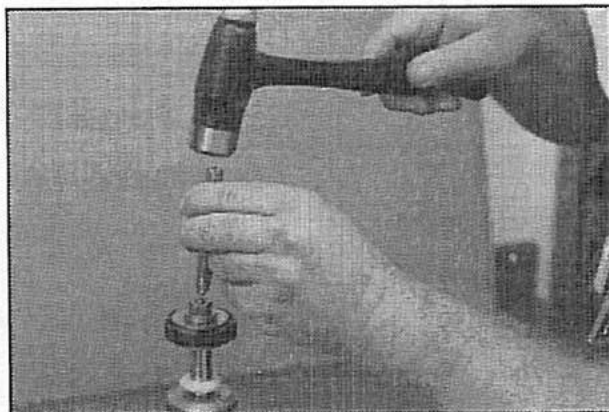

6. Using a punch with pointed end, stake the rod end in at least two places to prevent the nut from coming loose.

Circlip Type - ASSEMBLY PROCEDURES

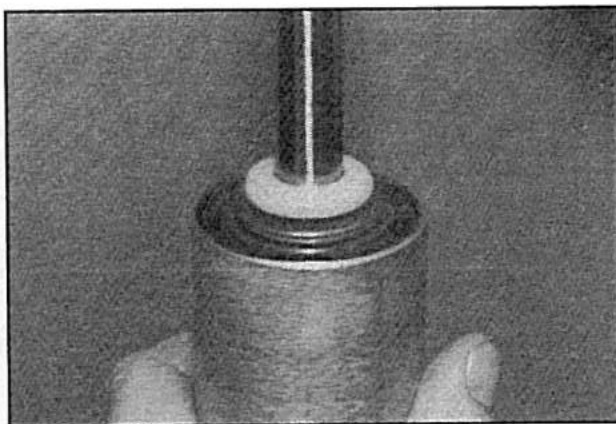

1. Lubricate the tube bore with a small amount of shock fluid, and insert the dividing piston (see diagram for correct orientation). With a brass rod, drive the dividing piston into the tube to a depth of 260mm (10.25") from the top of the tube (For Winston Cup shocks). Vent air pressure through the fill valve while pushing the piston into the tube or remove the valve core.

2. Insert the piston rod with piston and valves into the tube. Install the inner snap ring into its groove.

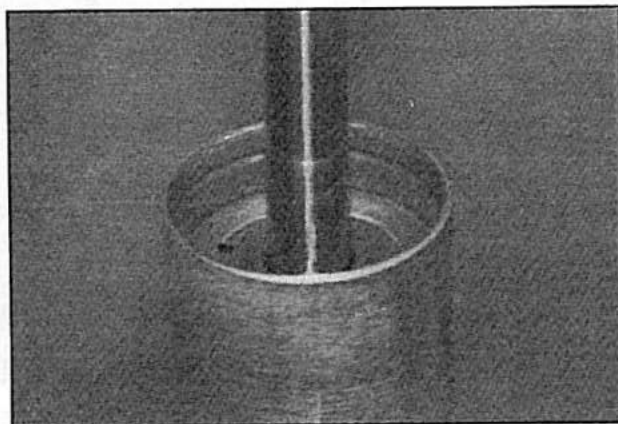
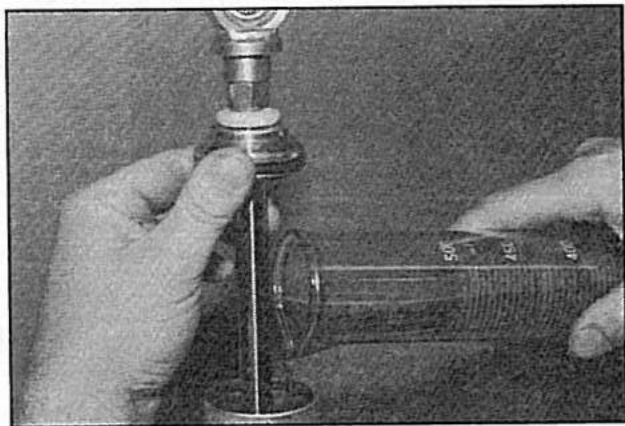

3. Measure the correct amount of fluid (320 ml for Winston Cup shocks) in the beaker (Part #193020), and pour into the shock tube. **DO NOT OVERFILL THE SHOCK.**

4. Place the inner plate squarely into the tube so that it rests on the snap ring.

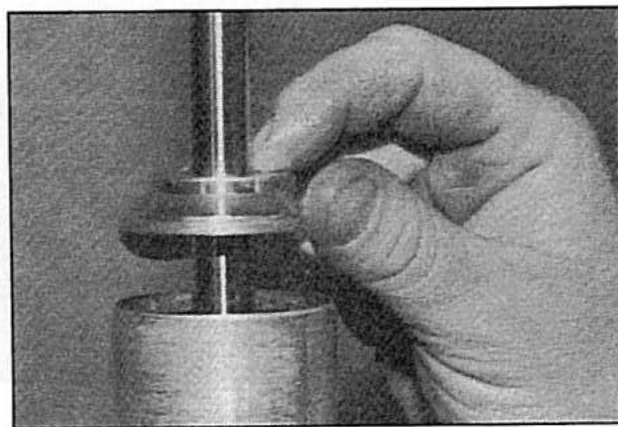
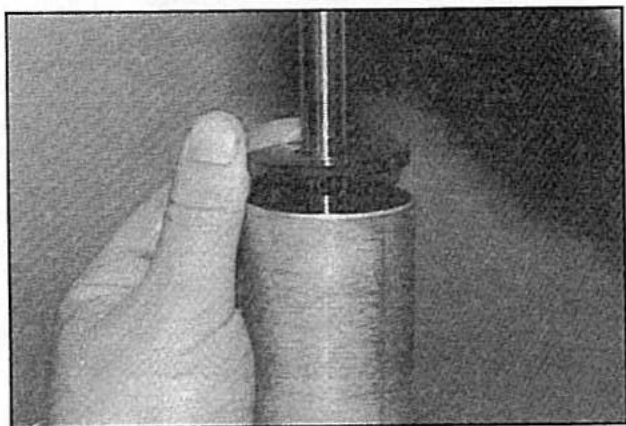

5. Set the large tube seal disc into the tube against the plate. Make sure the seal rests fully against the plate around the outside edge.

6. Carefully guide the rod seal down over the rod so that it seats into the tube seal disc. Push the rod guide down onto the seals by hand.

(more)

Circlip Type - *ASSEMBLY PROCEDURES*

Continued

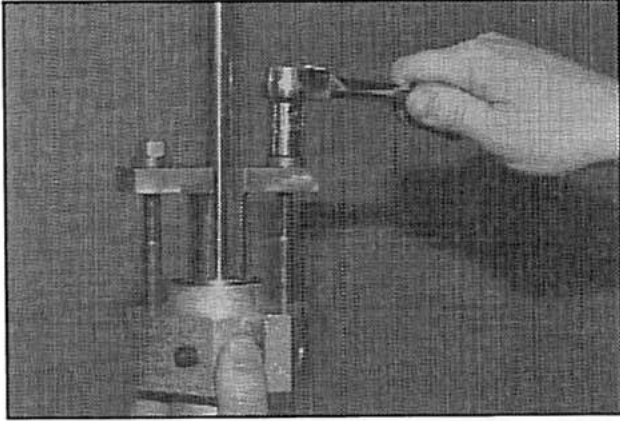

7. Install the clamp tool onto the shock and tighten the clamp bolt. Tighten the two nuts evenly to compress the guide enough to allow the outer snap ring to be installed.

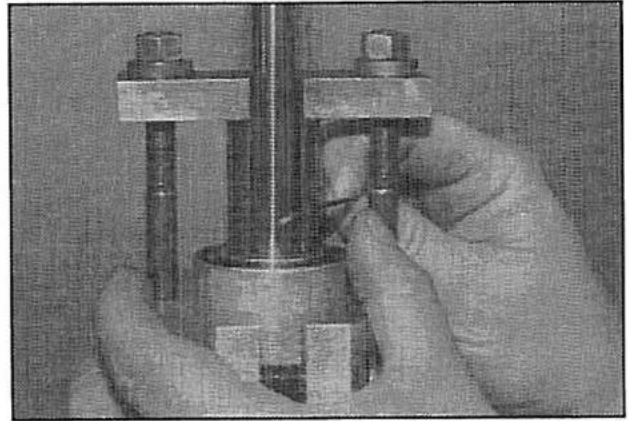

8. Install the outer snap ring making sure it is fully seated in its groove. Back off the two nuts on the clamp tool to approximately 6 mm (1/4"). **Do not remove the tool yet.**

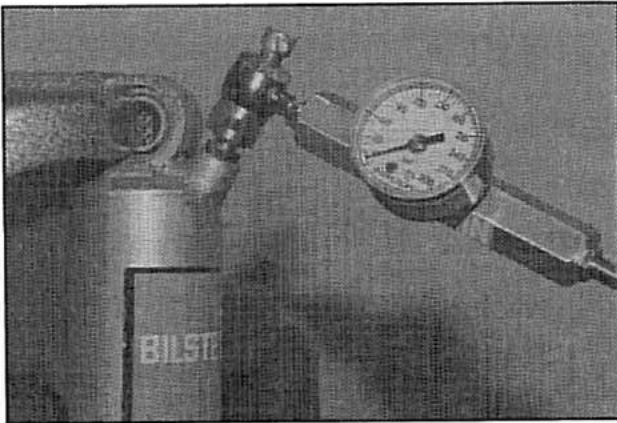

9. Install gas-filling tool (Part #193000) onto the Schrader valve and apply nitrogen gas to the shock (180 psi minimum).

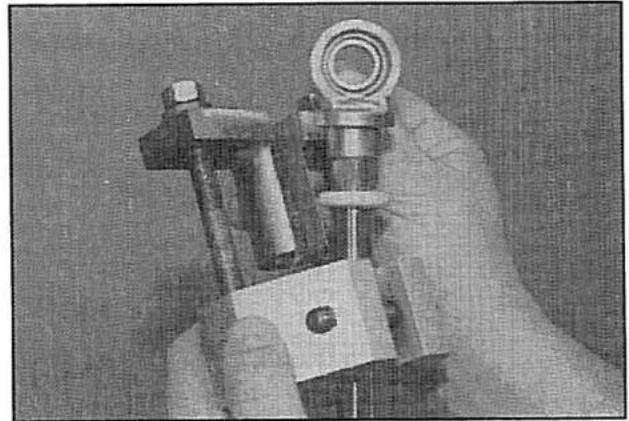

10. Recheck that the snap ring is seated properly, and if it is, remove the clamp tool.

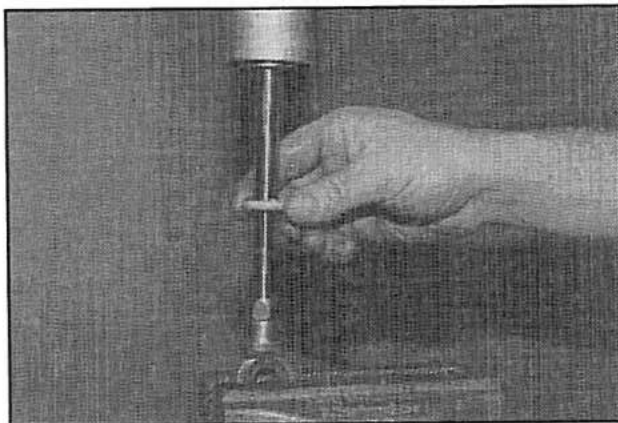

11. Install the travel indicator, jam, nut, thread adhesive and the heim end if removed during disassembly.

Threaded Rod Guide Type - *DISASSEMBLY PROCEDURES*



1. With the tube end heim mount held in a soft jaw vice, release all gas pressure from the shock through the Schrader valve.

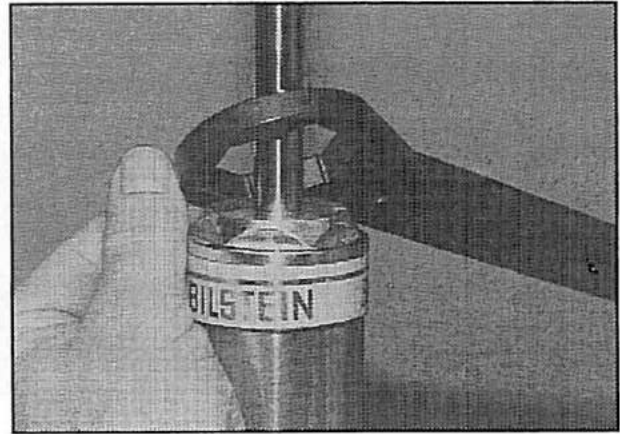

2. Keeping the shock body in the same position, remove the rod guide nut, where the piston rod enters the shock tube, using the uni-directional Bilstein wrench (Part #193070).



3. Slowly pull the piston rod, with rod guide assembly and piston head assembly, out of the shock tube.

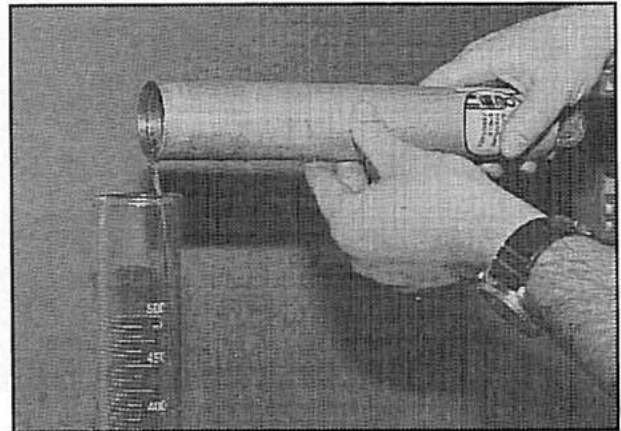

4. Pour the shock oil from the tube into a clean beaker (Part #193020). If needed, discard the used fluid and replace it with new Bilstein shock oil.

Threaded Rod Guide Type - *REVALVING PROCEDURES*

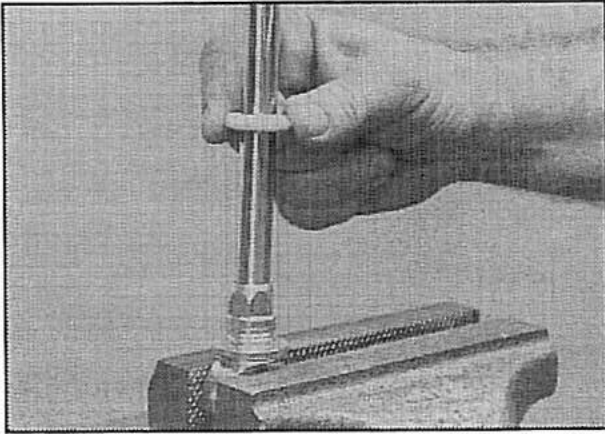

1. Secure the piston rod end mount, with the piston upward, into a conventional vice (or use a vice equipped with soft jaws suitable for holding the 14mm (0.55") diameter piston rod). The moveable travel indicator will be located between the rod mount and threaded rod guide assembly.

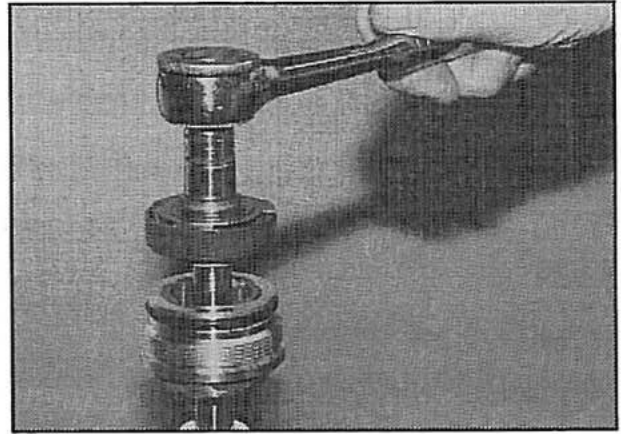

2. Remove the nylock nut holding the piston assembly together. This will allow the valving discs on top of the piston head assembly to be removed.

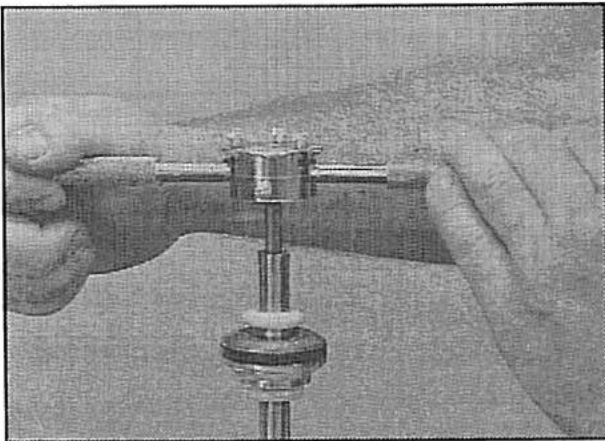

3. If no nylock nut is used, you have the option of chasing the threads on the piston rod using a M8 X 1 die (Part #193050). No chasing is required with the nylock nut.

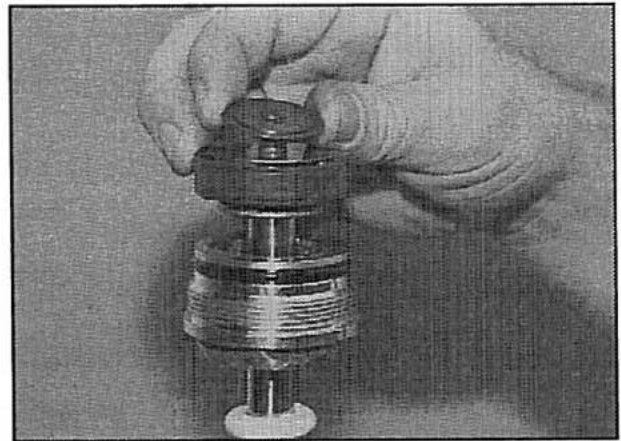

4. Assemble the new valve components and piston onto the piston rod tenon, referring to the appropriate valving sheet (For example: 480/160D DIGRESSIVE).

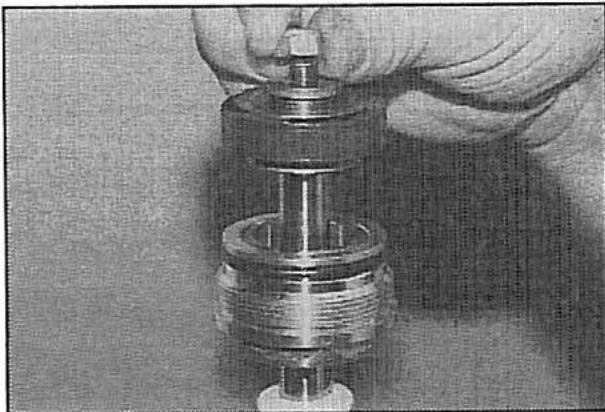

5. Reattach the nylock nut and torque to the specifications noted on the valving sheet in the manual.

Threaded Rod Guide Type - ASSEMBLY PROCEDURES

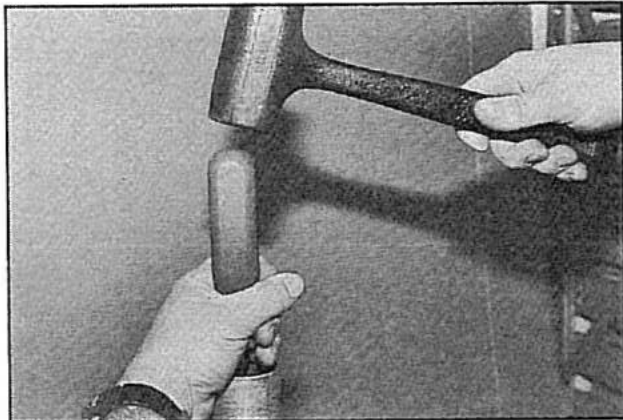

1. If the dividing piston was removed during revalving, insert the dividing piston into the shock tube and push it to the bottom using a wooden or brass rod.

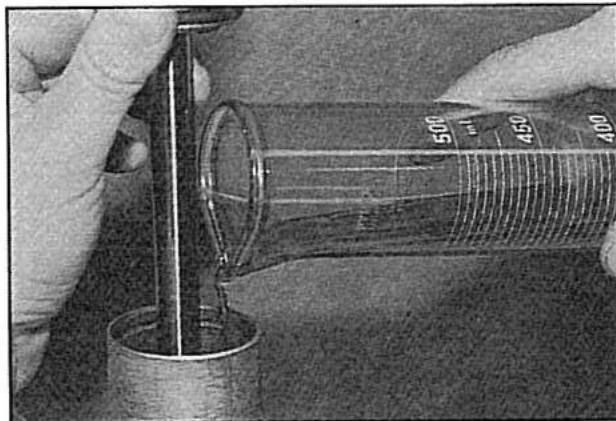

2. Measure the correct amount of fluid (320ml for Winston Cup/Busch GN and 8" travel shocks) in the beaker (Part #193020) and pour it into the shock tube. **DO NOT OVERFILL THE SHOCK.**



3. Insert the revalved piston head assembly and valve guide assembly into the shock tube carefully so there is no fluid overflow.

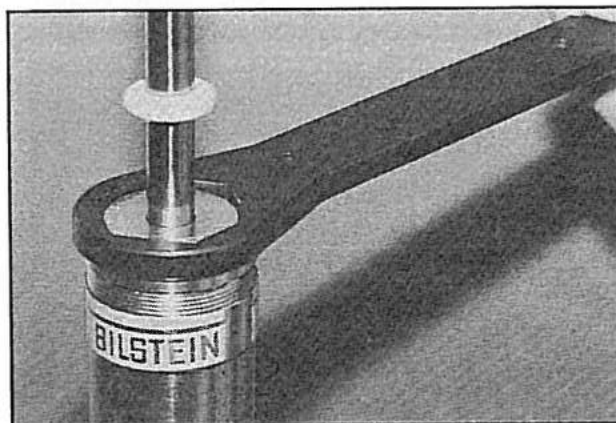

4. Tighten the rod guide nut securely to the shock tube using the uni-directional Bilstein wrench (part # 193070).

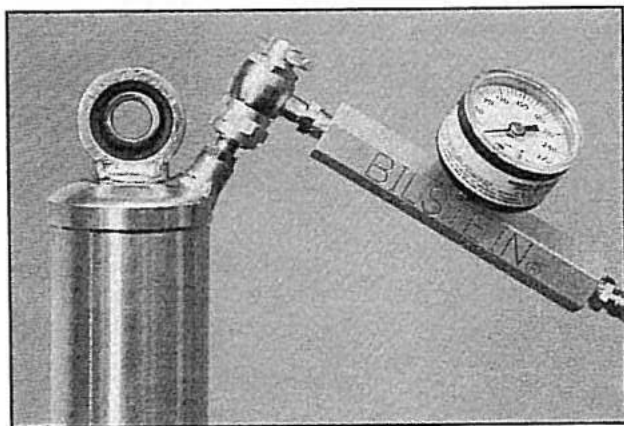

5. Reposition the shock in the vice and attach the gas-filling tool (Part #193000) onto the Schrader valve. Apply nitrogen gas to the shock (180 psi minimum).

Large Nitrogen Compartment Series - *DISASSEMBLY PROCEDURES*

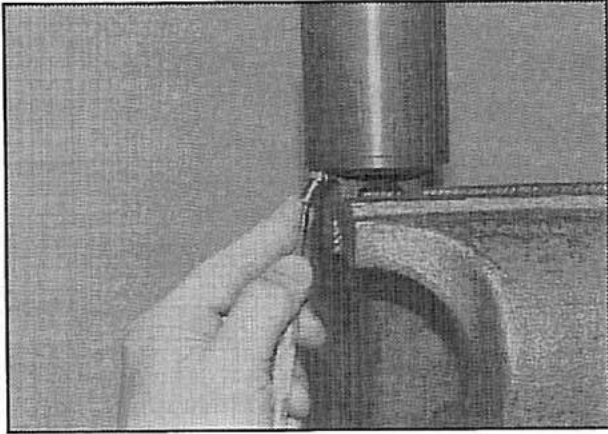

1. With the tube end heim mount held in a soft jaw vice, release all gas pressure from the shock through the Schrader valve.

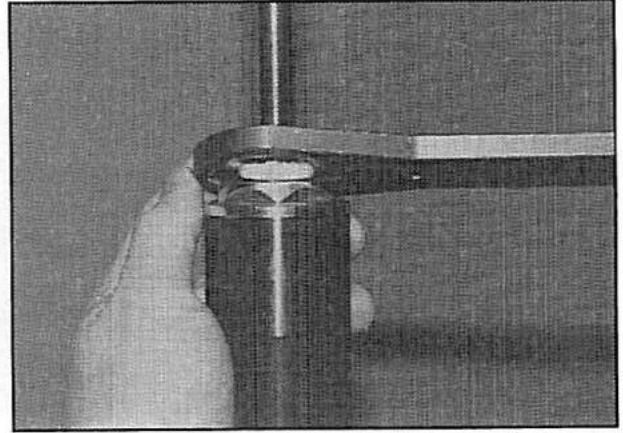

2. Keeping the shock body in the same position, remove the rod guide nut, where the piston rod enters the shock tube, using the uni-directional Bilstein wrench (Part #193070).

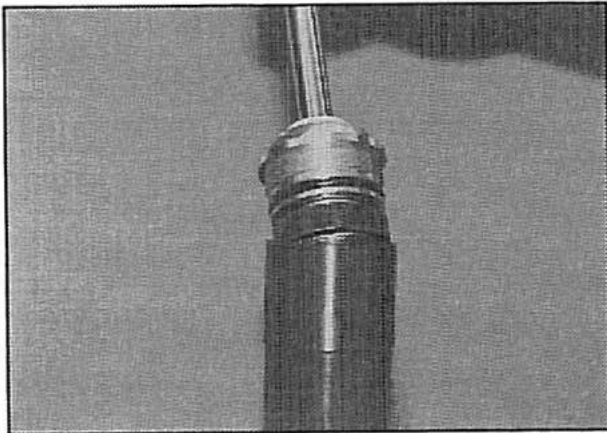

3. Slowly pull the piston rod, with rod guide assembly and piston head assembly, out of the shock tube.

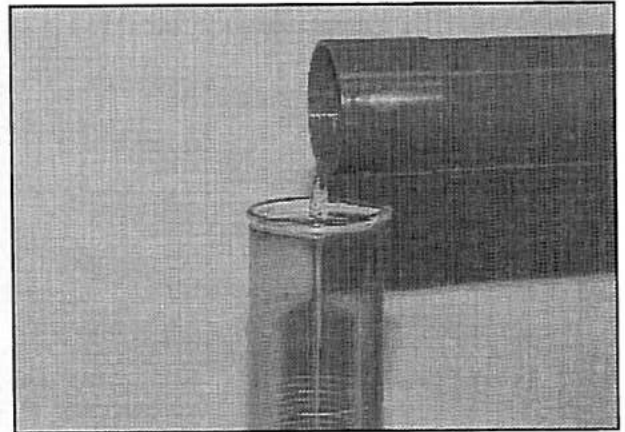

4. Pour the shock oil from the tube into a clean beaker (Part #193020). If needed, discard the used fluid and replace it with new Bilstein shock oil.

Large Nitrogen Compartment Series - REVALVING PROCEDURES

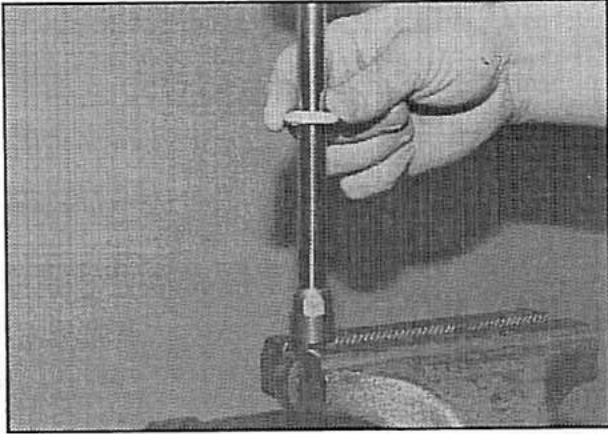

1. Secure the piston rod end mount, with the piston upward, into a conventional vice (or use a vice equipped with soft jaws suitable for holding the 14mm (0.55") diameter piston rod). The moveable travel indicator will be located between the rod mount and threaded rod guide assembly.

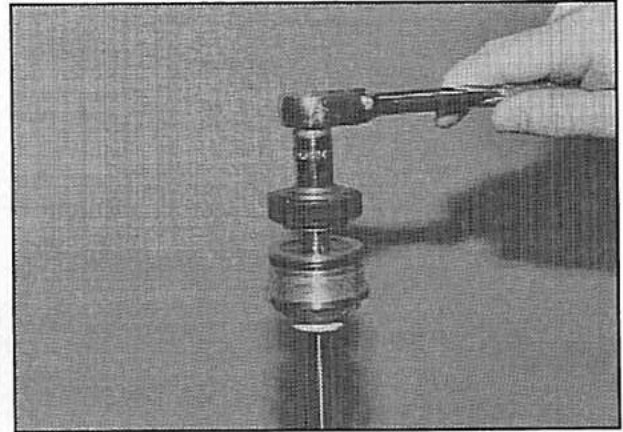

2. Remove the nylock nut holding the piston assembly together. This will allow the valving discs on top of the piston head assembly to be removed.

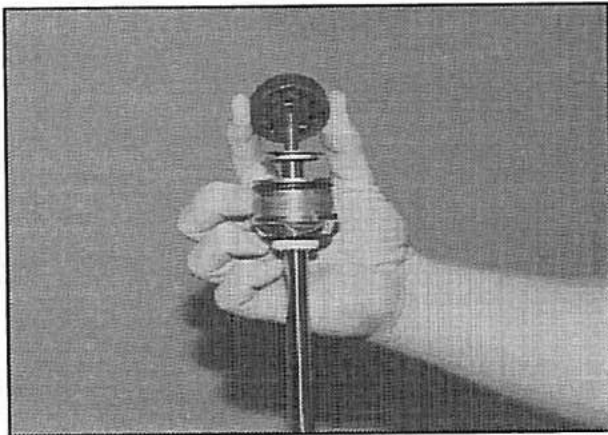

3. Remove and discard the M8X1 nylock nut. Then remove the piston and discard all valve parts.

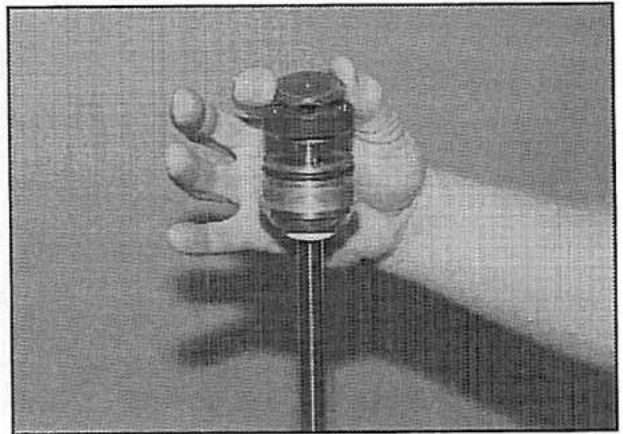

4. Assemble the new valve components and piston onto the piston rod tenon, referring to the appropriate valving sheet (For example: 480/160D DIGRESSIVE).

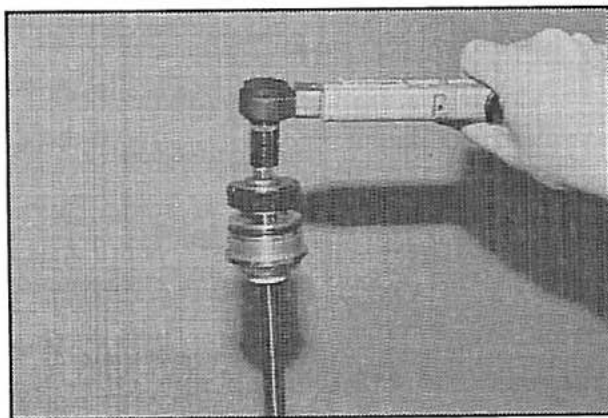

5. Reattach the nylock nut and torque to the specifications noted on the valving sheet in the manual.

Large Nitrogen Compartment Series - *ASSEMBLY PROCEDURES*

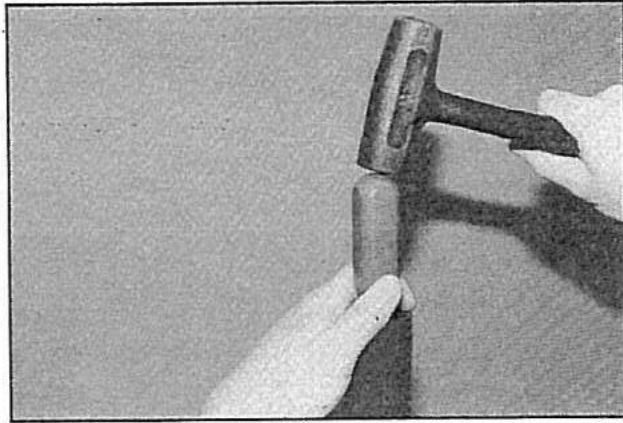

1. If the dividing piston was removed during revalving, insert the dividing piston into the large nitrogen separator chamber and push it to the bottom using a wooden or brass rod.

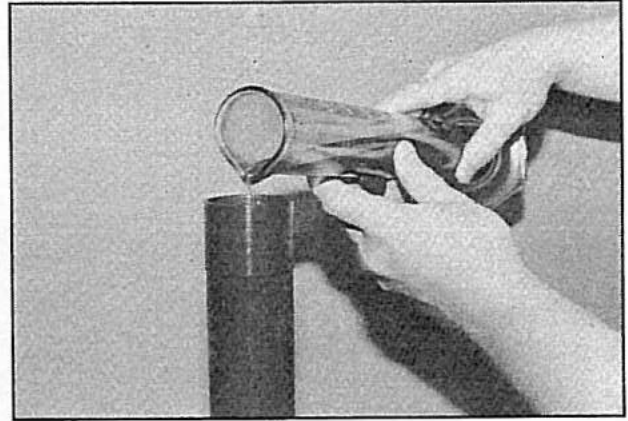

2. Measure the correct amount of fluid (390ml for Winston Cup/Busch Series 8" travel shocks) in the beaker (Part #193020) and pour it into the shock tube, DO NOT OVERFILL THE SHOCK.



3. Insert the revalved piston head assembly and valve guide assembly into the shock tube carefully so there is no fluid overflow.

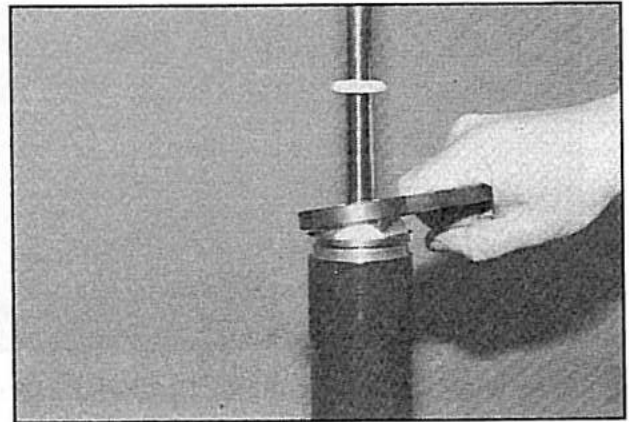

4. Tighten the rod guide nut securely to the shock tube using the Bilstein wrench. DO NOT OVER TIGHTEN.

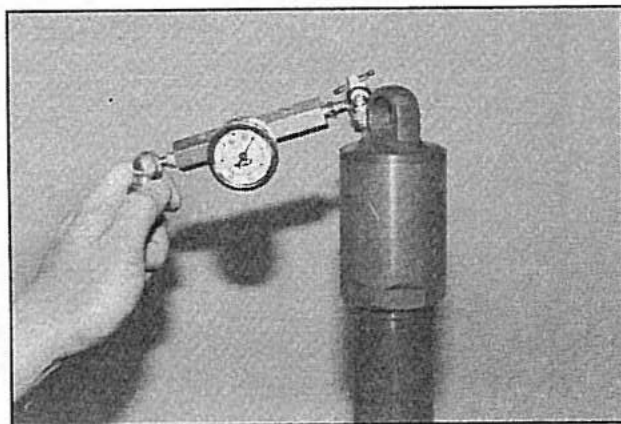

5. Reposition the shock in the vice and attach the gas-filling tool (Part #193000) onto the Schrader valve. Then apply nitrogen gas to the shock (180 psi minimum).

Rebuildable-Revalvable Series - *DISASSEMBLY PROCEDURES*

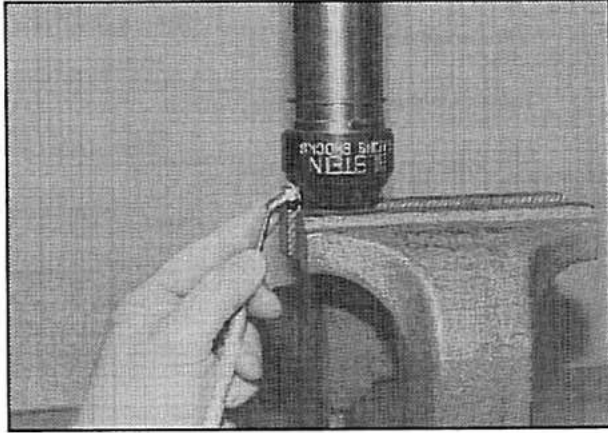

1. Release all gas pressure from the shock through the Schrader valve.

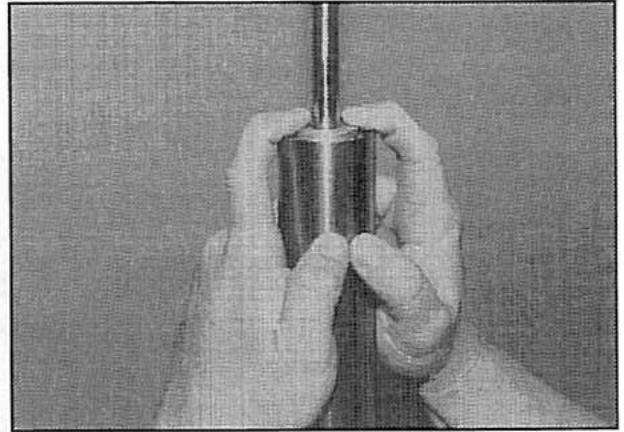

2. Using your fingers, depress the rod guide away from the upper snap ring.

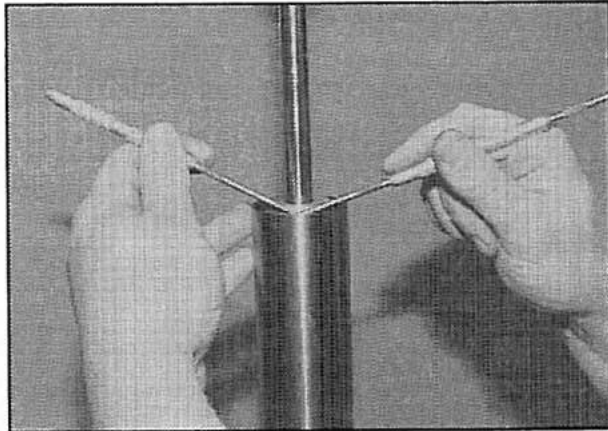

3. Using Bilstein picks (Part #193040), remove the upper snap ring.

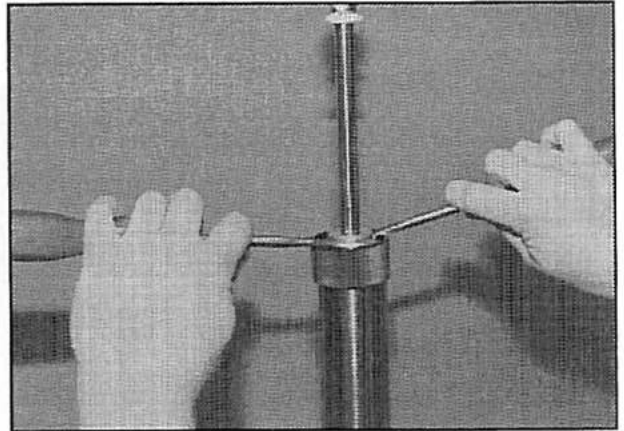

4. Using the Bilstein disassembly collar (Part #193343) as a fulcrum point, pry the rod guide out of the tube using two flat-bladed screw drivers. NOTE: Do not use excessive force.

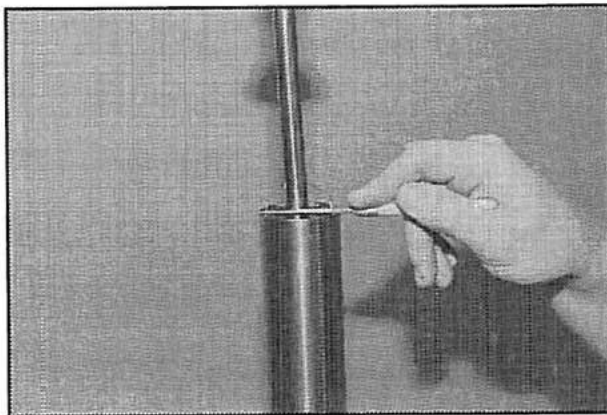

5. Remove the lower snap ring, taking care not to scratch the tube bore.

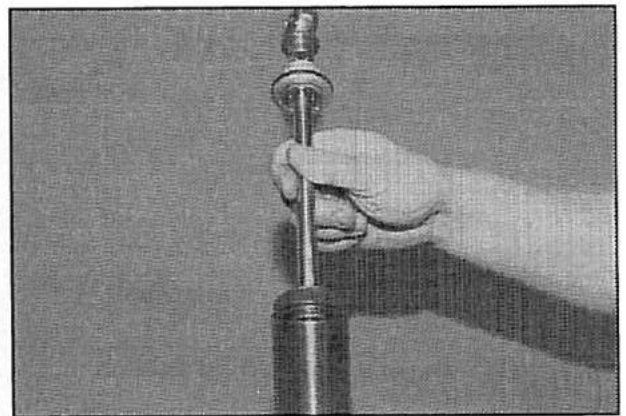

6. Slowly pull the piston rod, with piston and valves upwards, out of the shock body. Pour the fluid into a clean beaker (Part #193020). If needed, discard the used fluid and replace it with new Bilstein shock oil.

Rebuildable-Revalvable Series - REVALVING PROCEDURES

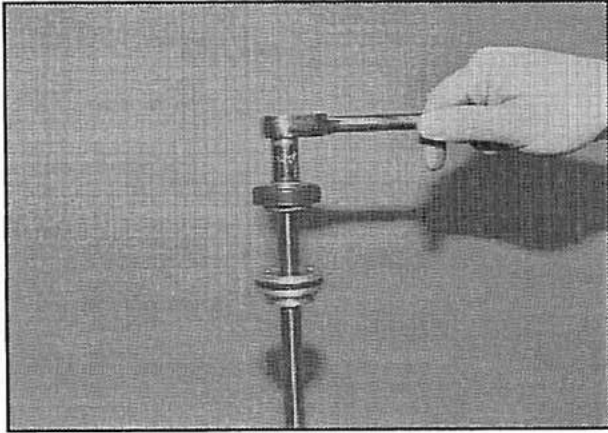

1. Remove the nylock nut holding the piston assembly together.

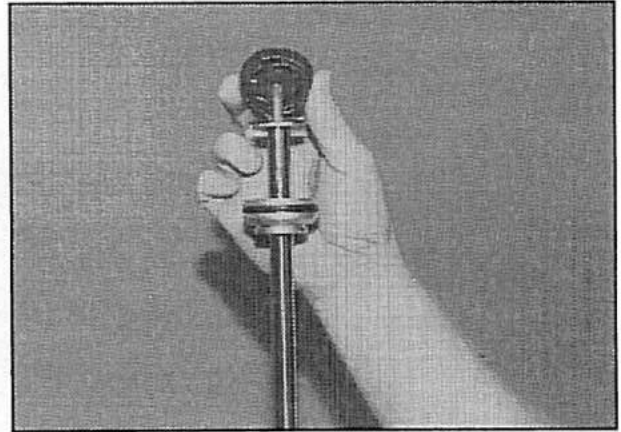

2. Remove the valve stack from the shaft and return it to its slot in your valving kit.

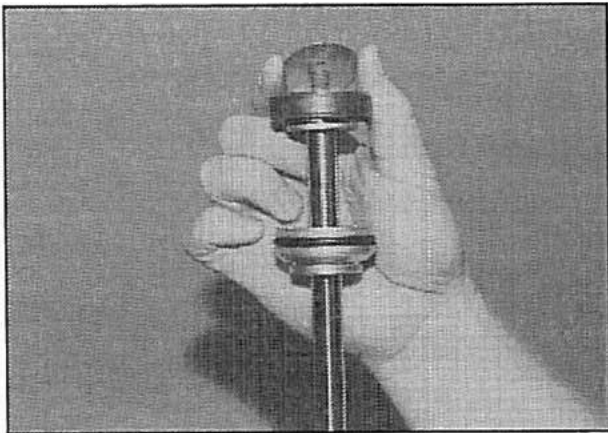

3. Assemble the new valve components (chosen from the valving kit) onto the rod tenon. Always check orientation of plates against the valvings provided in this manual.

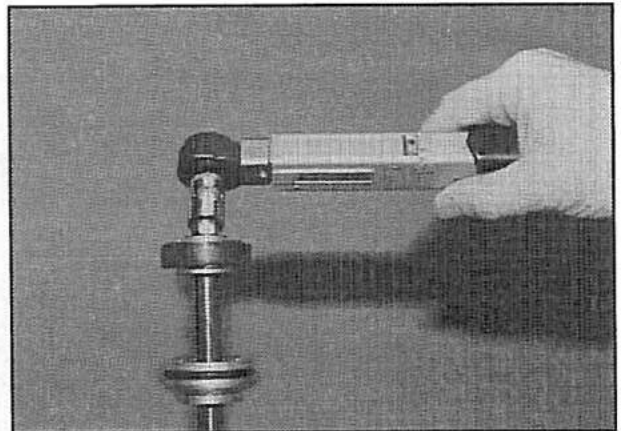

4. Install a new hex nut and tighten to specification on the valving sheet.

Rebuildable-Revalvable Series - ASSEMBLY PROCEDURES

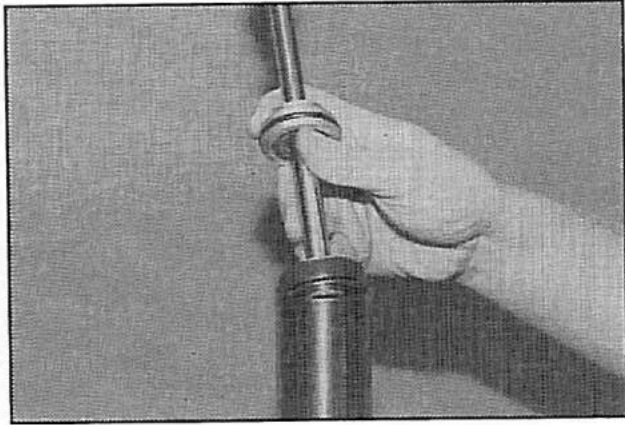

1. Insert the piston rod with piston and valves into the tube.

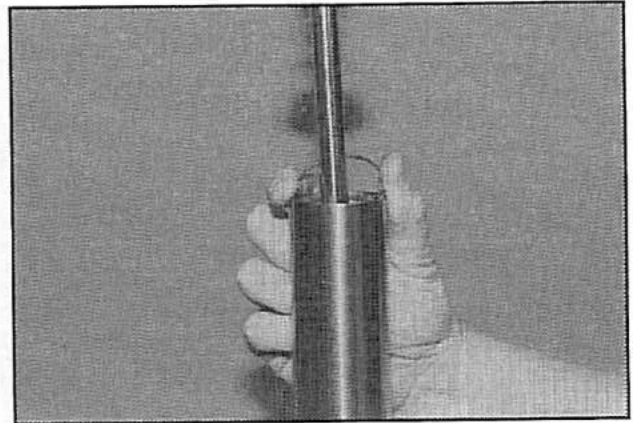

2. Install the lower snap ring into its groove inside the bore.

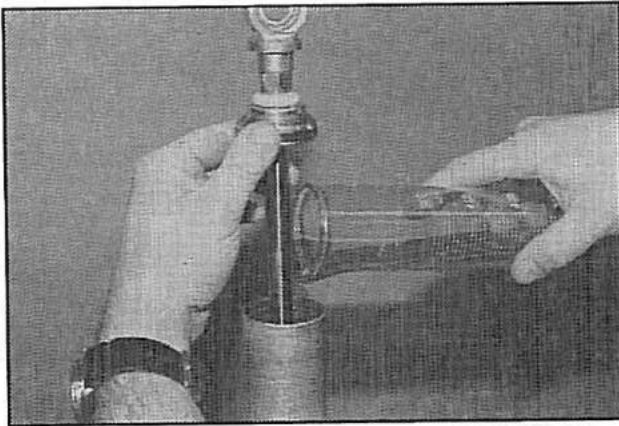

3. Measure the correct amount of fluid (See spec sheet in binder) in the beaker (Part #193020), and pour it into the shock tube. **DO NOT OVERFILL THE SHOCK.**

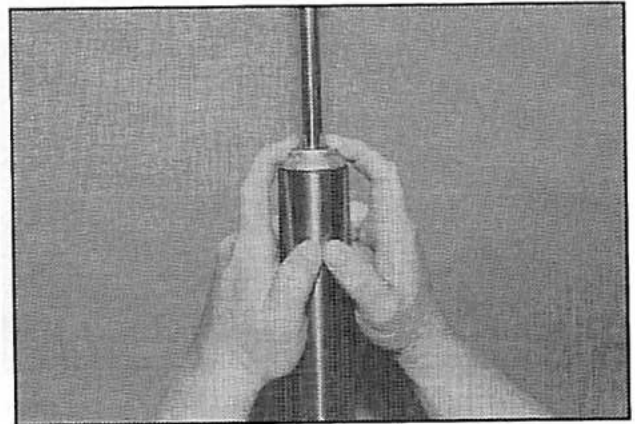

4. Using your fingers, depress the rod guide down onto the lower snap ring.

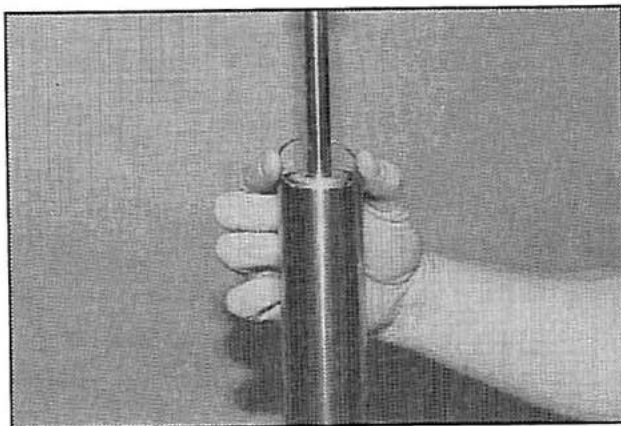

5. Install the upper snap ring.

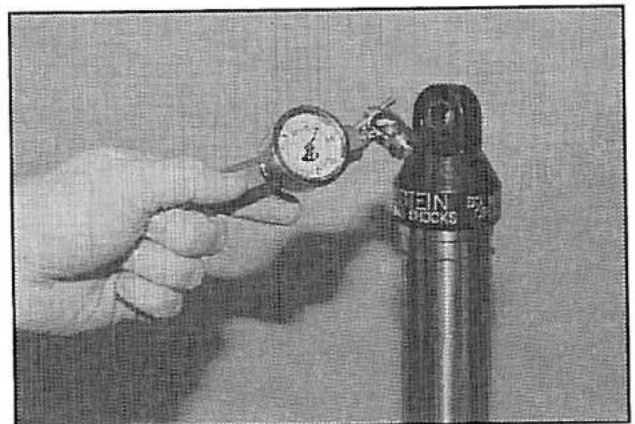

6. Install the gas-filling tool (Part #193000) onto the Schrader valve, and apply nitrogen gas to the shock (180 psi minimum).

Econo Aluminum Series (ATAD/ATAL Type) - **DISASSEMBLY PROCEDURES**

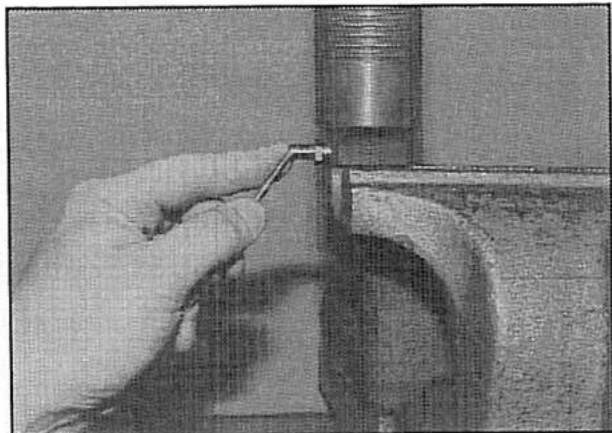

1. Release all gas pressure from the shock through the Schrader valve.

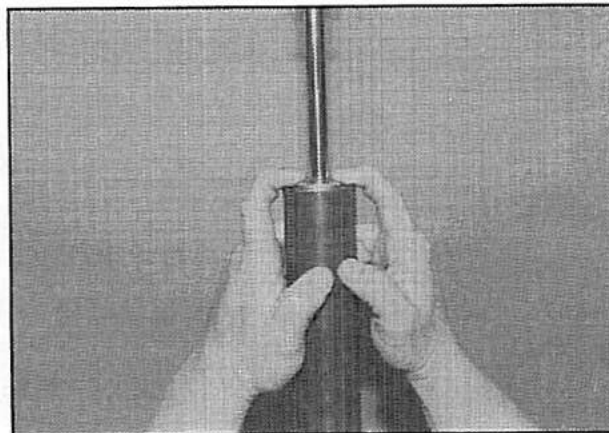

2. Using your fingers, depress the rod guide away from the upper snap ring.

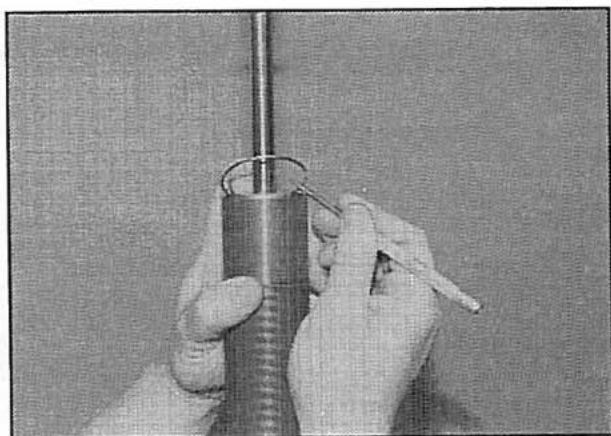

3. Using Bilstein picks (Part #193040), remove the upper snap ring.

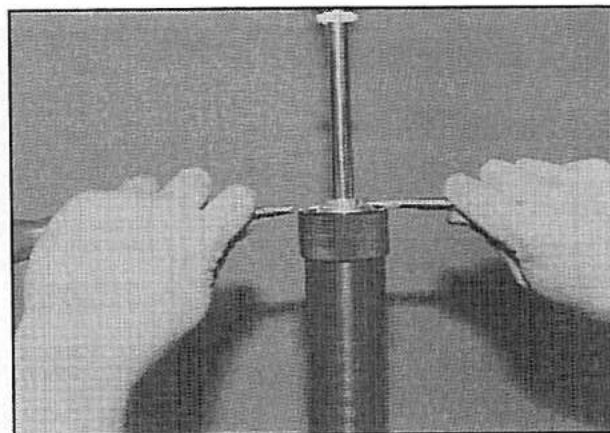

4. Using the Bilstein disassembly collar (Part #193343) as a fulcrum point, pry the rod guide out of the tube using two flat-bladed screw drivers. **NOTE: Do not use excessive force.**

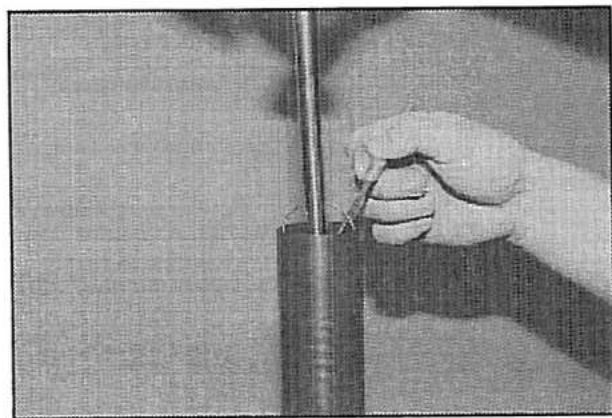

5. Remove the lower snap ring, taking care not to scratch the tube bore.

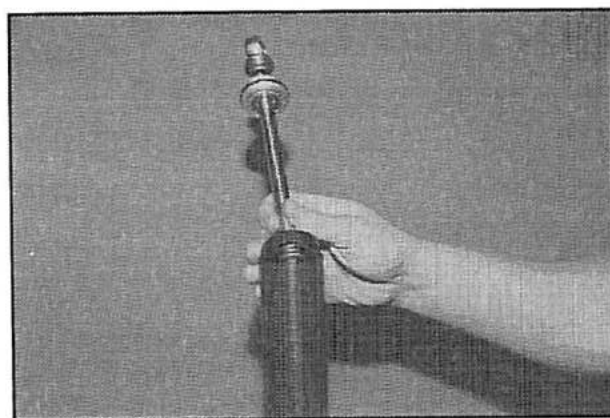

6. Slowly pull the piston rod, with piston and valves upwards, out of the shock body. Pour the fluid into a clean beaker (Part #193020). If needed, discard the used fluid and replace it with new Bilstein shock oil.

Econo Aluminum Series (ATAD/ATAL Type) - **REVALVING PROCEDURES**

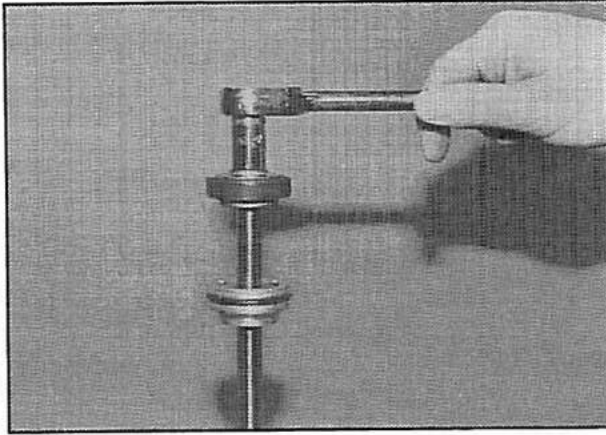

1. Remove the nylock nut holding the piston assembly together.

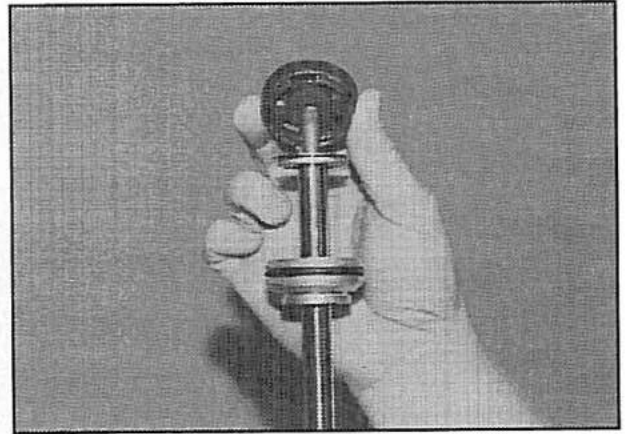

2. Remove the valve stack from the shaft and return it to its slot in your valving kit.

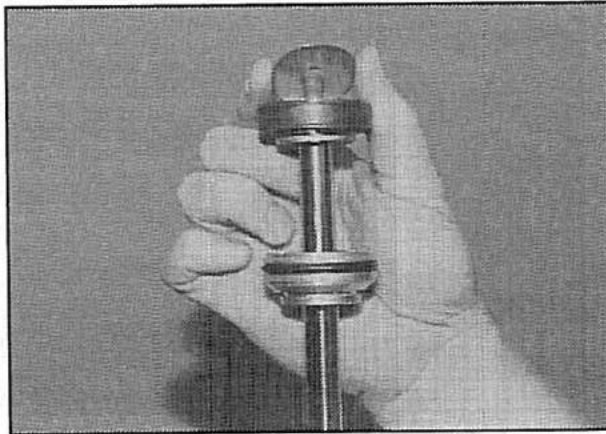

3. Assemble the new valve components (chosen from the valving kit) onto the rod tenon. Always check orientation of plates against the valvings provided in this manual.

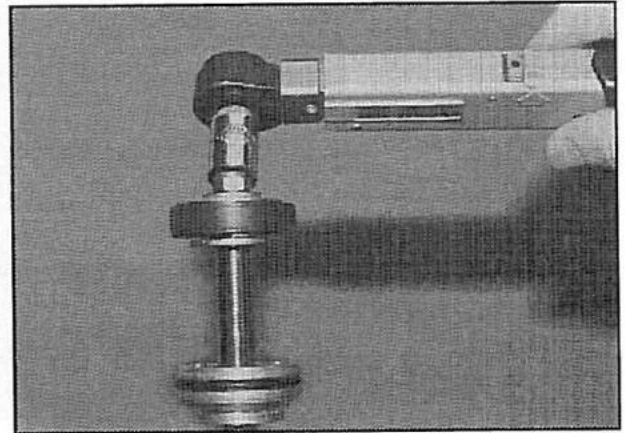

4. Install a new hex nut and tighten to specification on the valving sheet.

Econo Aluminum Series (ATAD/ATAL Type) - ASSEMBLY PROCEDURES

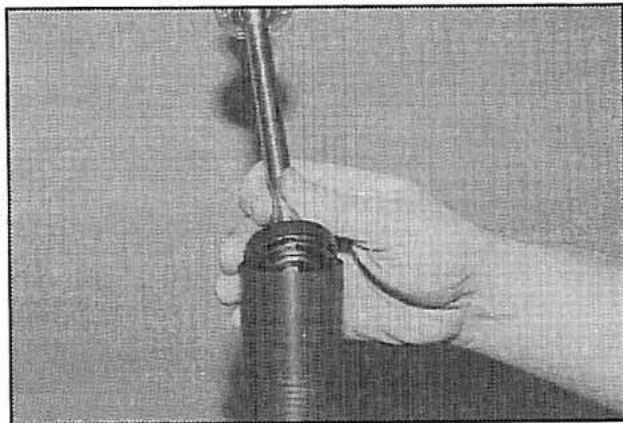

1. Insert the piston rod with piston and valves into the tube.

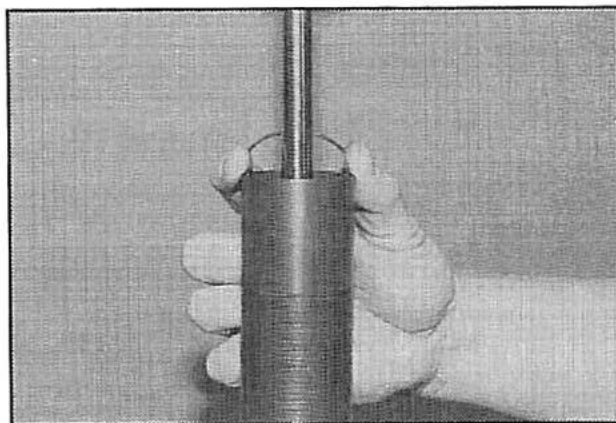

2. Install the lower snap ring into its groove inside the bore.

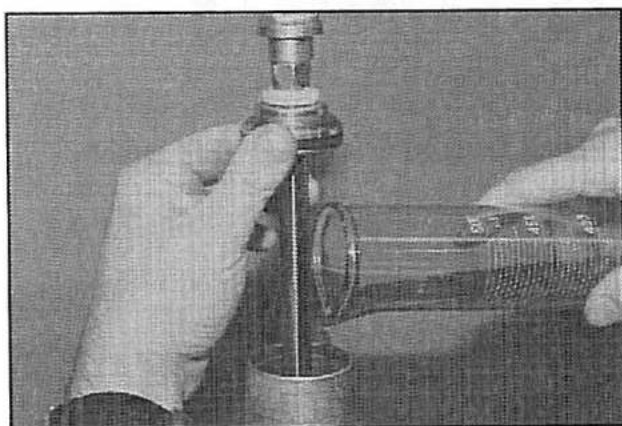

3. Measure the correct amount of fluid (See spec sheet in binder) in the beaker (Part #193020), and pour it into the shock tube. **DO NOT OVERFILL THE SHOCK.**

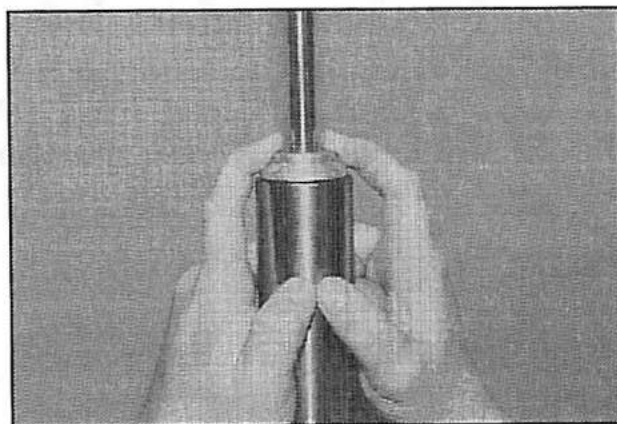

4. Using your fingers, depress the rod guide down onto the lower snap ring.

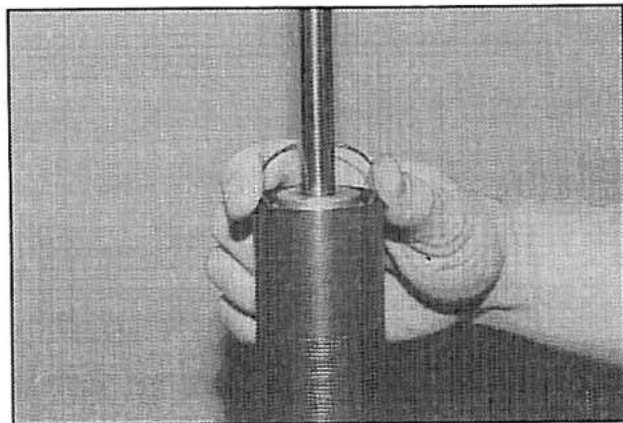

5. Install the upper snap ring.

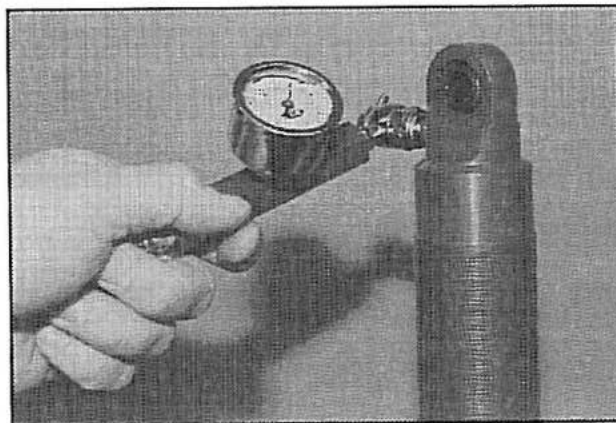

6. Install the gas-filling tool (Part #193000) onto the Schrader valve and apply nitrogen gas to the shock (180 psi minimum).

Short Track Linear & Digressive Valving Specifications

VALVING: _____ (LINEAR)

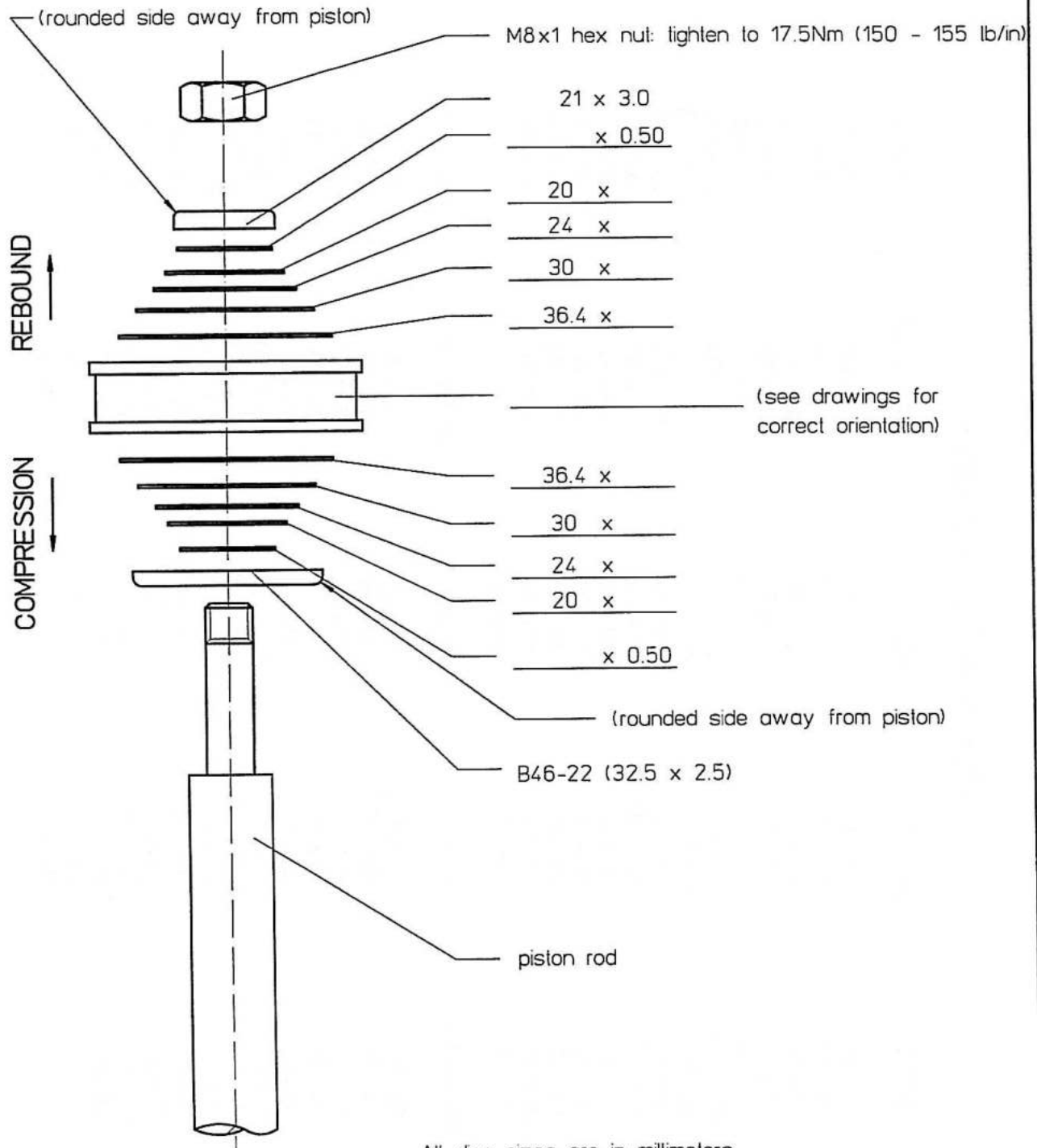

All disc sizes are in millimeters

example:

"30 x 0.30" is 30mm diameter, 0.30mm thick



Oval Track Linear Valvings

230/78 "A"	208/72 "B"	162/55 "C"	220/120 "D"	270/90 "E"
21 x 3F 16 x 50 20 x 40 24 x 35 30 x 30 36.4 x 30 B46-U37T 18 x 10 36.4 x 20 30 x 25 24 x 30 20 x 40 18.5 x 50 B46-22	21 x 3F 15 x 50 20 x 40 24 x 35 30 x 30 36.4 x 25 B46-U37T 18 x 10 36.4 x 20 30 x 20 24 x 30 20 x 50 20 x 50 B46-22	21 x 3F 13 x 50 20 x 25 24 x 30 30 x 30 36.4 x 30 B46-U37T 18 x 10 36.4 x 20 30 x 20 24 x 20 20 x 20 16 x 50 B46-22	21 x 3F 14.5 x 50 20 x 35 24 x 35 30 x 35 36.4 x 35 B46-U37T 36.4 x 30 30 x 30 24 x 35 20 x 40 17.5 x 50 B46-22	21 x 3F 14 x 50 20 x 30 24 x 35 30 x 35 36.4 x 40 B46-U37T 36.4 x 25 30 x 30 24 x 30 20 x 35 16.5 x 50 B46-22
300/100 "H"	180/95 "L"	180/120 "R"	230/100 "S"	200/180 "U"
21 x 3F 15 x 50 20 x 35 24 x 35 30 x 35 36.4 x 45 B46-U37T 36.4 x 20 30 x 25 24 x 25 20 x 50 20 x 50 B46-22	21 x 3F 14.5 x 50 20 x 35 24 x 35 30 x 30 36.4 x 30 B46-U37T 18 x 10 36.4 x 25 30 x 30 30 x 25 24 x 30 20 x 50 20 x 50 B46-22	21 x 3F 13.5 x 50 20 x 35 24 x 35 30 x 35 36.4 x 30 B46-U37T 36.4 x 25 30 x 30 24 x 35 20 x 40 17 x 50 B46-22	21 x 3F 16 x 50 20 x 40 24 x 35 30 x 30 36.4 x 30 B46-U37T 18 x 10 36.4 x 30 30 x 30 24 x 30 20 x 40 18 x 50 B46-22	21 x 3F 13 x 50 20 x 30 24 x 30 30 x 40 36.4 x 40 B46-U37T 36.4 x 40 30 x 35 24 x 35 20 x 40 18 x 50 B46-22

VALVING: _____ (DIGRESSIVE)

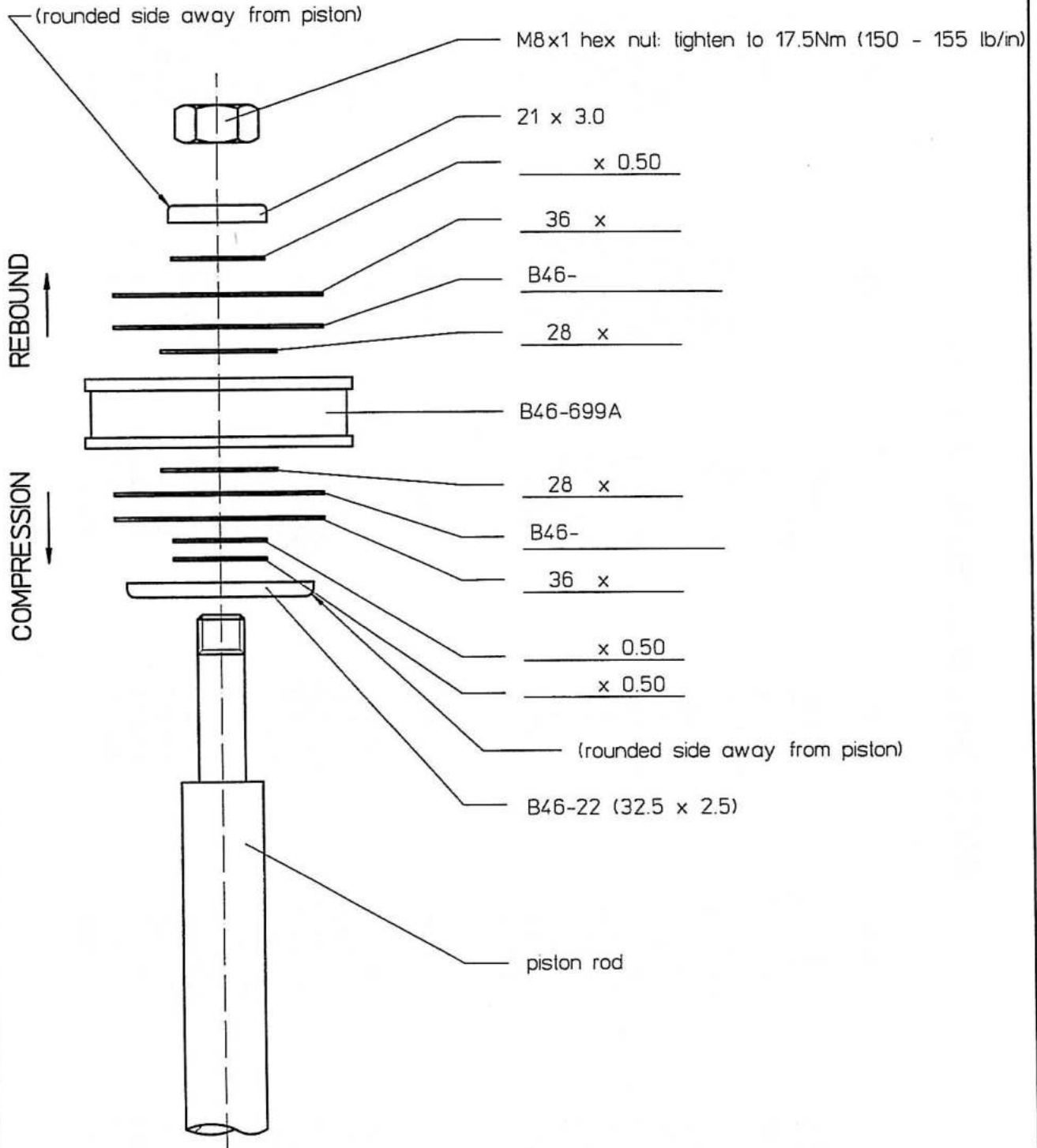

All disc sizes are in millimeters

example:

"36 x 0.50" is 36mm diameter, 0.50mm thick



Bilstein Short Track Digressive Valvings

"3530"	21 x 3C 18.5 x 0.50 36 x 0.35 B46-744B1 28 x 0.30 B46-699A 28 x 0.25 B46-744C1 36 x 0.40 17.5 x 0.50 17.5 x 0.50 B46-22	"3030"	21 x 3C 18.5 x 0.50 18.5 x 0.50 36 x 0.40 B46-744B1 28 x 0.30 B46-699A 28 x 0.30 B46-744B1 36 x 0.40 17 x 0.50 17 x 0.50 B46-22	"6065"	21 x 3C 18 x 0.50 36 x 0.35 B46-742C1 28 x 0.15 B46-699A 28 x 0.10 B46-742C1 36 x 0.35 18 x 0.50 18 x 0.50 B46-22	"5570"	21 x 3C 18.5 x 0.50 36 x 0.30 B46-742C1 28 x 0.15 B46-699A 28 x 0.10 B46-742C1 36 x 0.40 18.5 x 0.50 18.5 x 0.50 B46-22	"6040"	21 x 3C 20 x 0.50 36 x 0.40 B46-743C1 28 x 0.20 B46-699A 28 x 0.20 B46-743C1 36 x 0.35 17 x 0.50 17 x 0.50 B46-22	"4010"	21 x 3C 18.5 x 0.50 36 x 0.40 B46-744B1 28 x 0.20 B46-699A 28 x 0.25 B46-744C1 36 x 0.25 17 x 0.50 17 x 0.50 B46-22
"3040"	21 x 3C 17 x 0.50 36 x 0.35 B46-744B1 28 x 0.20 B46-699A 28 x 0.25 B46-744C1 36 x 0.45 17.5 x 0.50 17.5 x 0.50 B46-22	"3060"	21 x 3C 17 x 0.50 36 x 0.35 B46-744B1 28 x 0.20 B46-699A 28 x 0.20 B46-743C1 36 x 0.45 19 x 0.50 19 x 0.50 B46-22	"1090"	21 x 3C 14 x 0.50 36 x 0.25 B46-744B1 28 x 0.45 B46-699A 28 x 0.10 36 x 0.50 14.5 x 0.50 14.5 x 0.50 B46-22	"3050"	21 x 3C 17 x 0.50 36 x 0.35 B46-744B1 28 x 0.20 B46-699A 28 x 0.20 B46-743C1 36 x 0.40 19 x 0.50 19 x 0.50 B46-22	"8040"	21 x 3C 16 x 0.50 36 x 0.50 B46-742A1 28 x 0.10 B46-699A 28 x 0.15 B46-743B1 36 x 0.35 15 x 0.50 15 x 0.50 B46-22	"5555"	21 x 3C 19.5 x 0.50 36 x 0.35 B46-743C1 28 x 0.20 B46-699A 28 x 0.15 B46-743C1 36 x 0.35 19 x 0.50 19 x 0.50 B46-22

Digressive Valvings..Cont.

"6020"	21 x 3C 20 x 0.50 36 x 0.40 B46-743C1 28 x 0.20 B46-699A 28 x 0.25 B46-744C1 36 x 0.35 17 x 0.50 17 x 0.50 B46-22	"6010"	21 x 3C 20 x 0.50 36 x 0.40 B46-743C1 28 x 0.20 B46-699A 28 x 0.25 B46-744C1 36 x 0.35 17 x 0.50 17 x 0.50 B46-22	"8060"	21 x 3C 20 x 0.50 36 x .050 B46-743B1 28 x 0.20 B46-699A 28 x 0.20 B46-743C1 36 x 0.50 18.5 x 0.50 18.5 x 0.50 B46-22	"5030"	21 x 3C 20 x 0.50 36 x 0.40 B46-743C1 28 x 0.20 B46-699A 28 x 0.25 B46-744C1 36 x 0.35 17.5 x 0.50 17.5 x 0.50 B46-22	"4555"	21 x 3C 18.5 x 0.50 36 x 0.40 B46-744B1 28 x 0.20 B46-699A 28 x 0.15 B46-743C1 36 x 0.35 19 x 0.50 19 x 0.50 B46-22	"7060"	21 x 3C 20 x 0.50 36 x 0.45 B46-743C1 28 x 0.20 B46-699A 28 x 0.20 B46-743C1 36 x 0.45 19 x 0.50 19 x 0.50 B46-22
"6060"	21 x 3C 20 x 0.50 36 x 0.40 B46-743C1 28 x 0.20 B46-699A 28 x 0.20 B46-743C1 36 x 0.40 19 x 0.50 19 x 0.50 B46-22	"7045"	21 x 3C 16 x 0.50 36 x 0.60 B46-743C1 28 x 0.25 B46-699A 28 x 0.15 B46-743C1 36 x 0.40 17 x 0.50 17 x 0.50 B46-22	"3545"	21 x 3C 17 x 0.50 36 x 0.40 B46-744B1 28 x 0.20 B46-699A 28 x 0.25 B46-744C1 36 x 0.45 18 x 0.50 18 x 0.50 B46-22	"5050"	21 x 3C 19 x 0.50 36 x 0.45 B46-744C1 28 x 0.30 B46-699A 28 x 0.20 B46-743C1 36 x 0.40 19 x 0.50 19 x 0.50 B46-22	"4040"	21 x 3C 18.5 x 0.50 36 x 0.40 B46-744B1 28 x 0.20 B46-699A 28 x 0.25 B46-744C1 36 x 0.45 17.5 x 0.50 17.5 x 0.50 B46-22	"7030"	21 x 3C 16.5 x 0.50 36 x 0.50 B46-742A1 28 x 0.10 B46-699A 28 x 0.25 B46-744A1 36 x 0.30 19 x 0.50 19 x 0.50 B46-22

GN Revalving Specifications

VALVING: 230/100 (LINEAR)

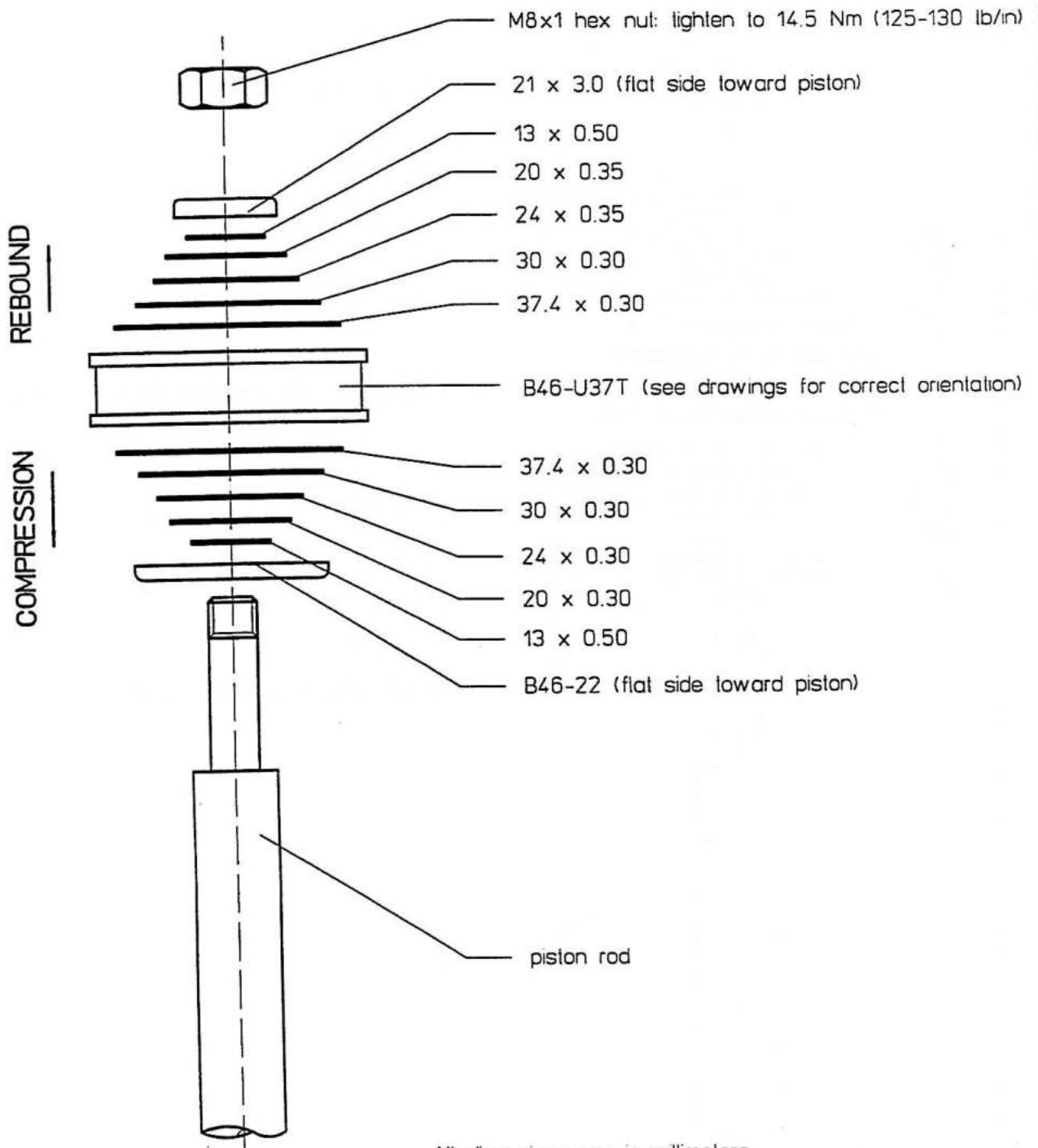

All disc sizes are in millimeters

example:

"30 x 0.30" is 30mm diameter, 0.30mm thick

VALVING: 275/110 (LINEAR)

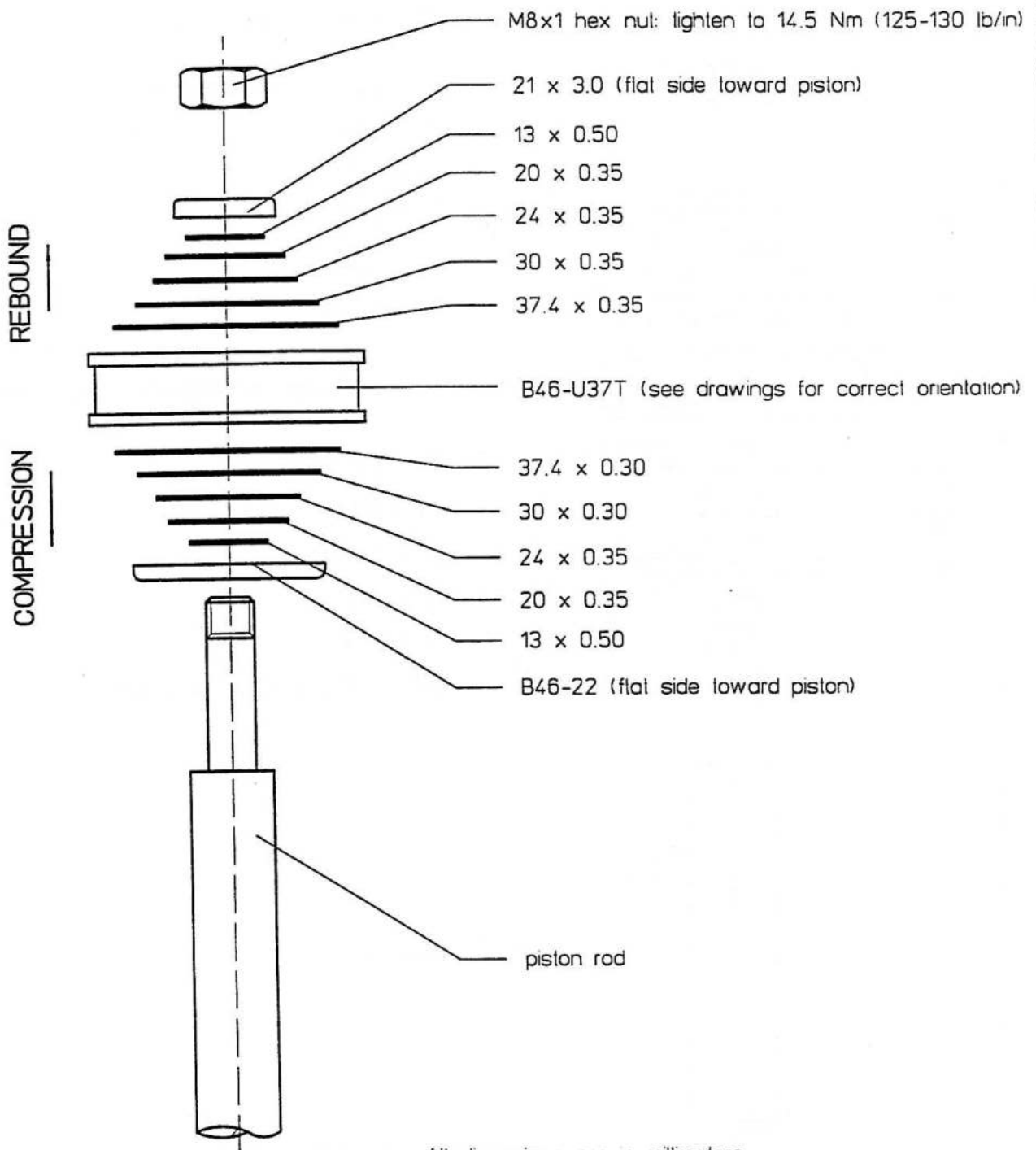

All disc sizes are in millimeters

example:

"30 x 0.30" is 30mm diameter, 0.30mm thick

VALVING: 300/150 (LINEAR)

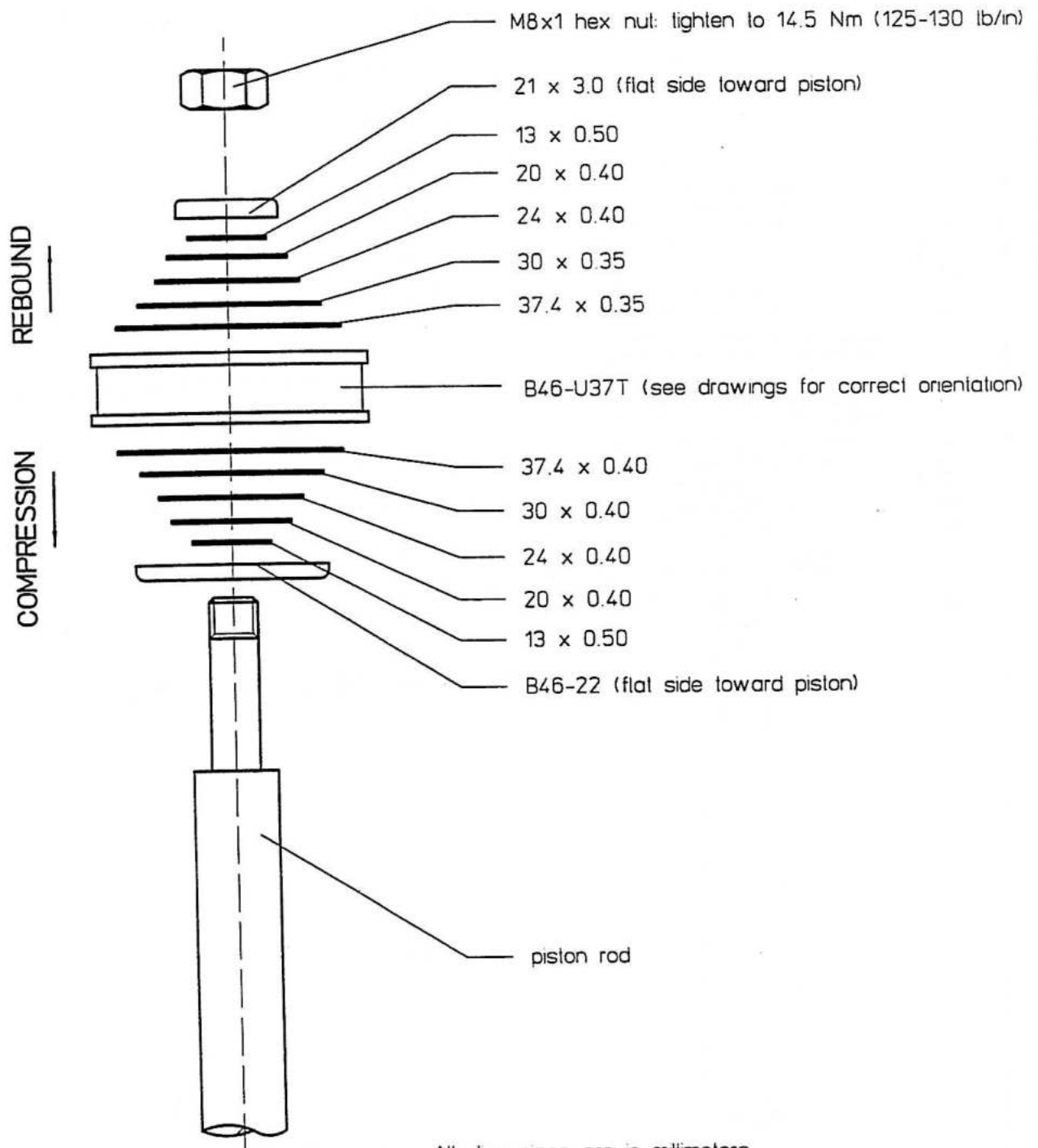

All disc sizes are in millimeters

example:

"30 x 0.30" is 30mm diameter, 0.30mm thick

VALVING: 325/110 (LINEAR)

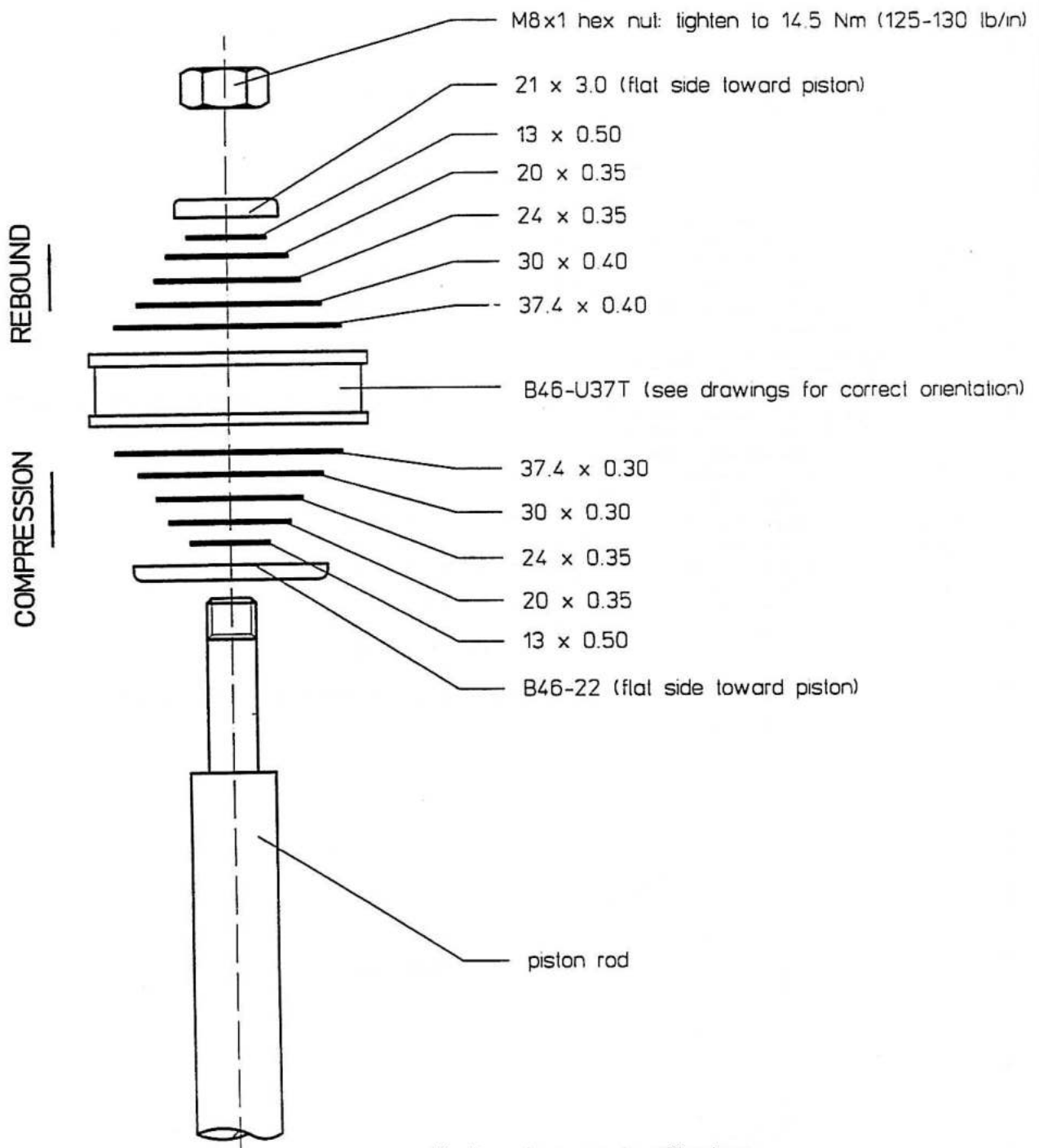

All disc sizes are in millimeters

example:

"30 x 0.30" is 30mm diameter, 0.30mm thick

VALVING: 325/125 (LINEAR)

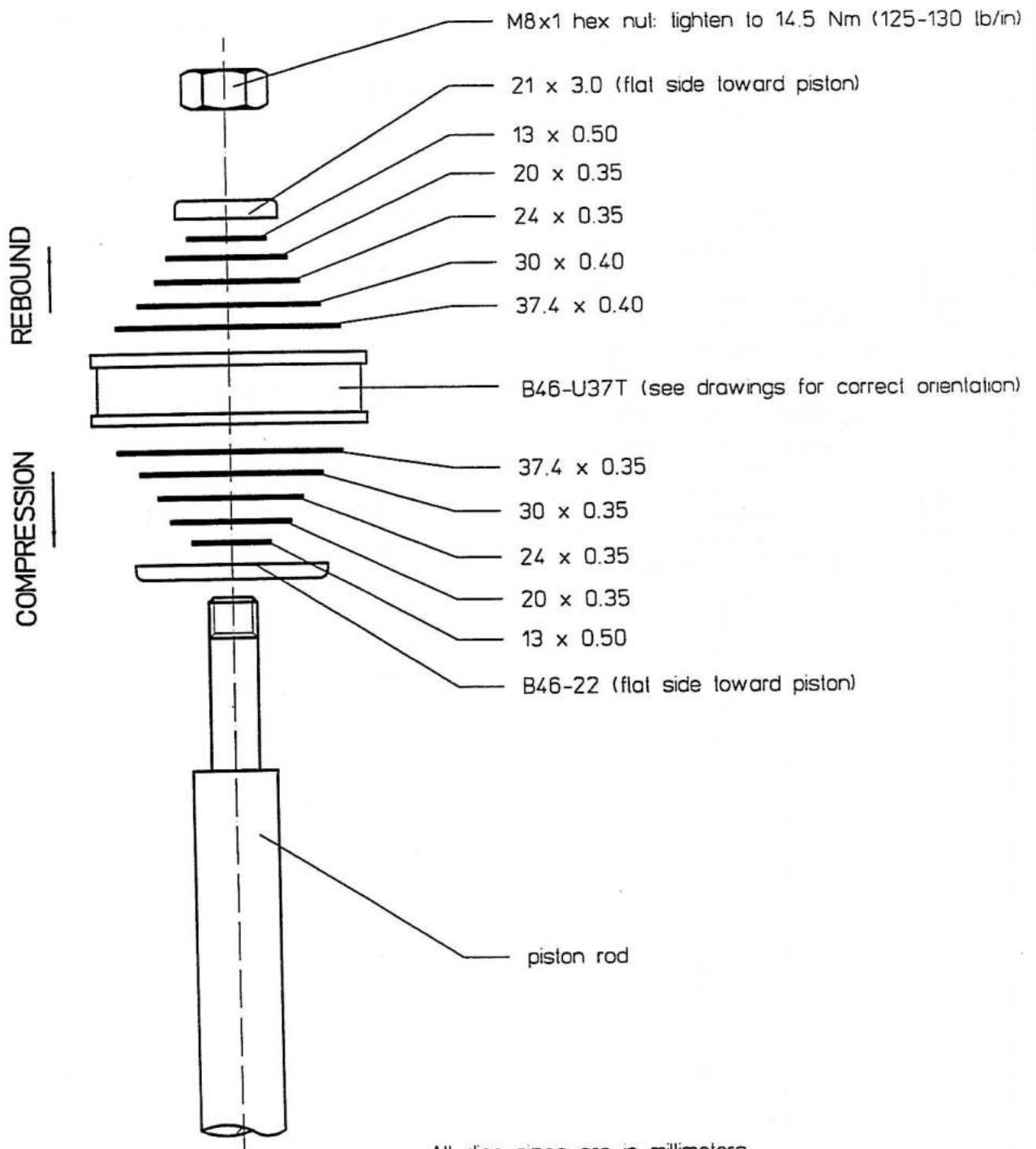

All disc sizes are in millimeters

example:

"30 x 0.30" is 30mm diameter, 0.30mm thick



VALVING: 345/135 (LINEAR)

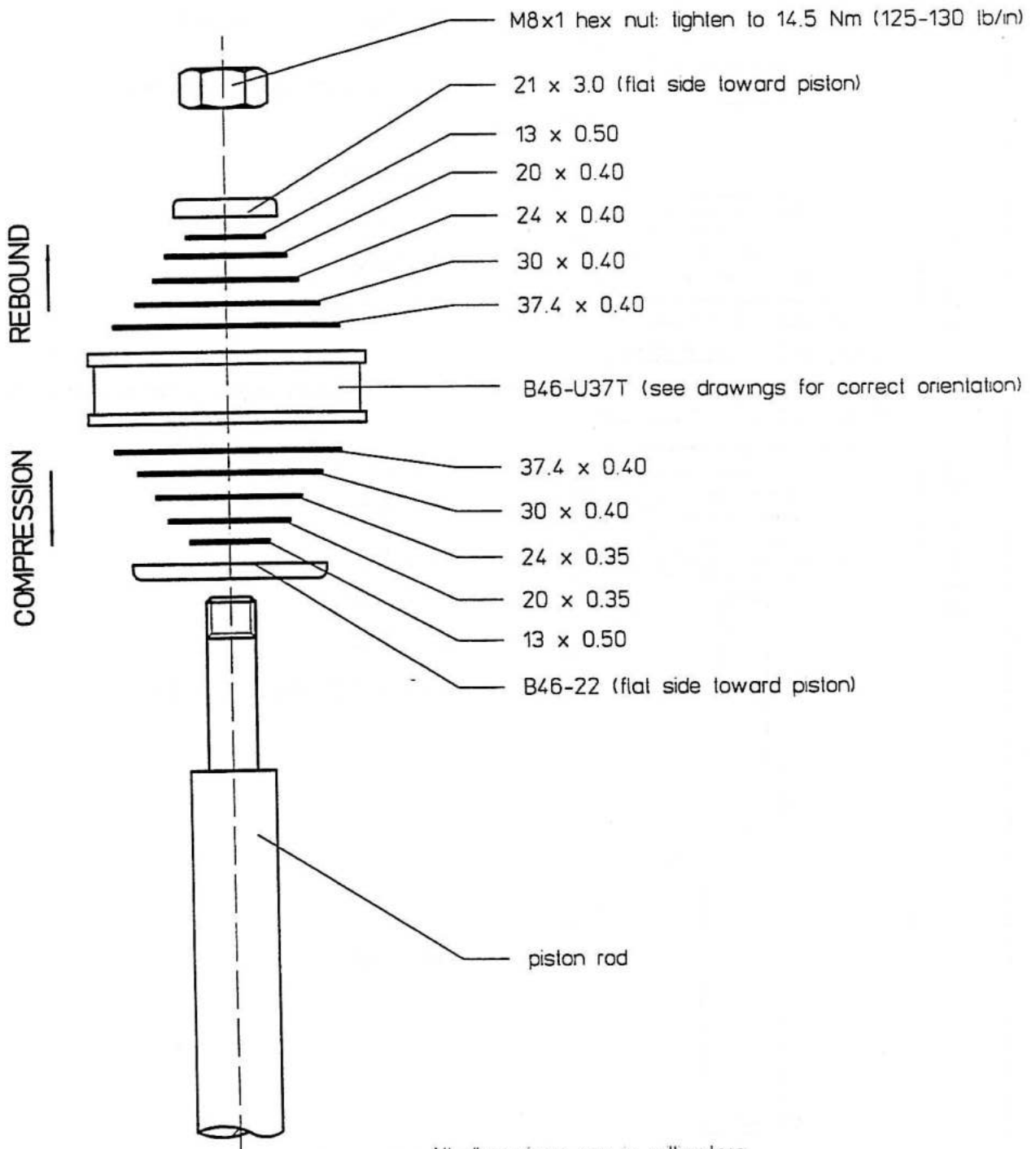

All disc sizes are in millimeters

example:

30 x 0.30 is 30mm diameter, 0.30mm thick

VALVING: 350/160 (LINEAR)

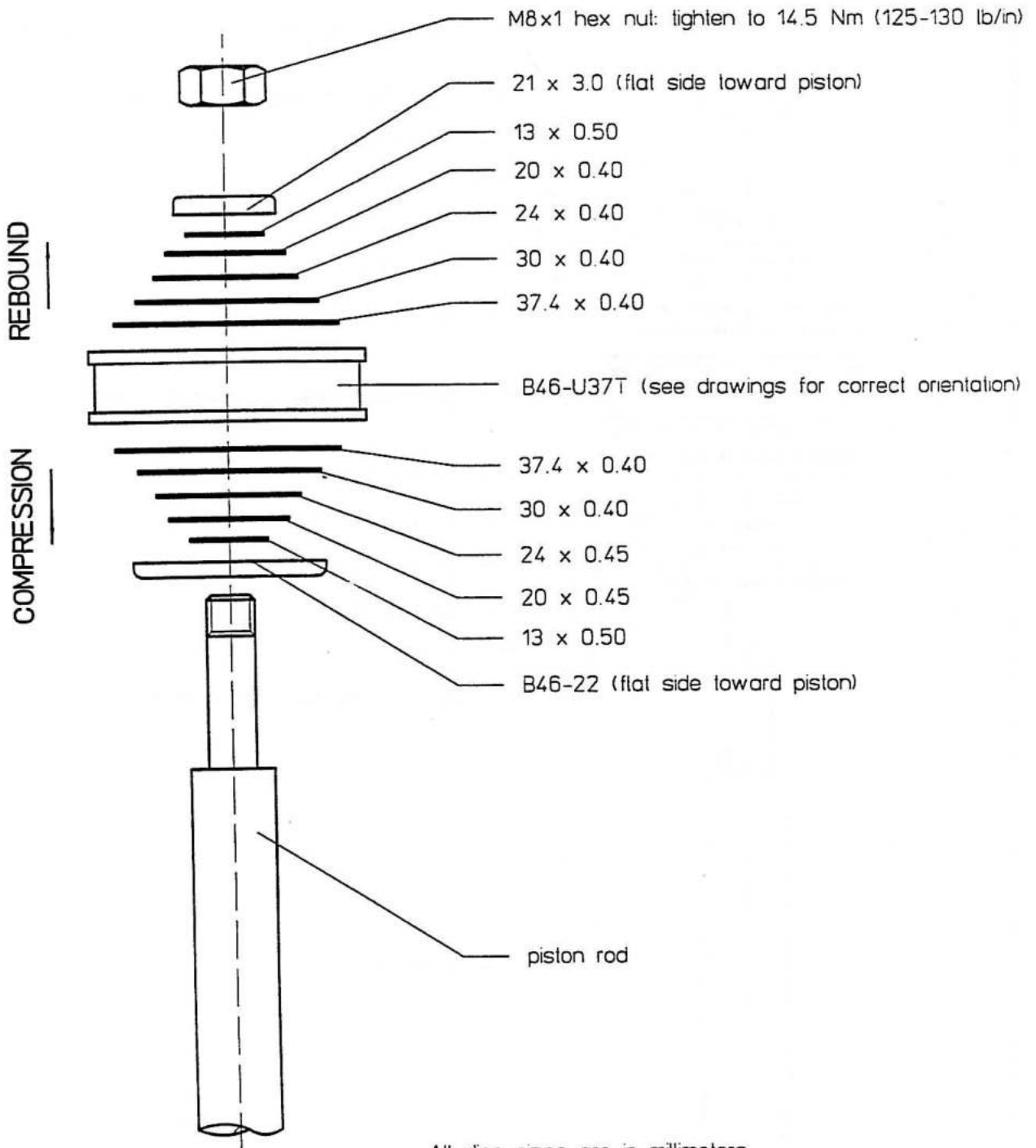

All disc sizes are in millimeters

example:

"30 x 0.30" is 30mm diameter, 0.30mm thick



VALVING: 380/160 (LINEAR)

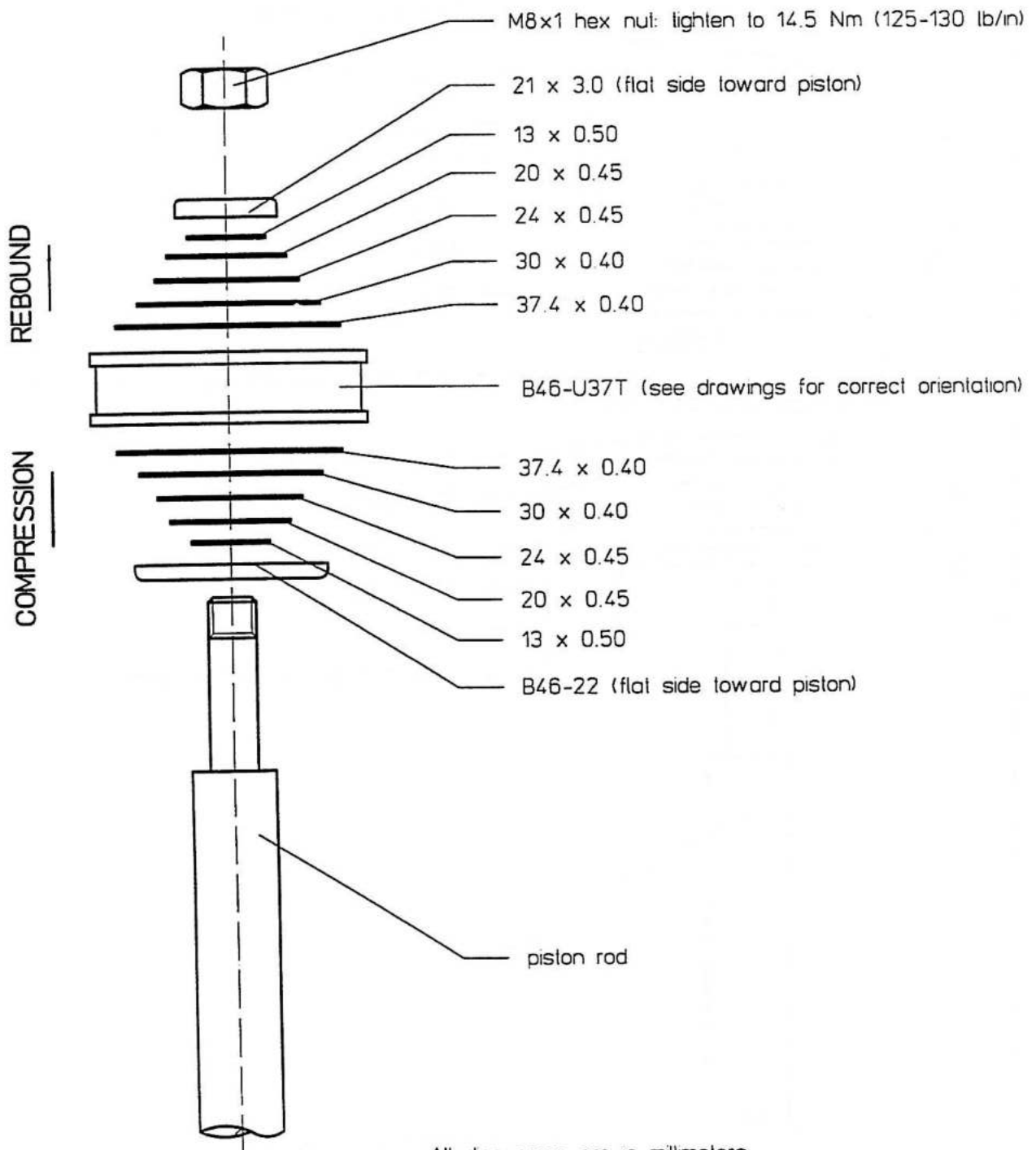

All disc sizes are in millimeters

example:

"30 x 0.30" is 30mm diameter, 0.30mm thick

VALVING: 390/150 (LINEAR)

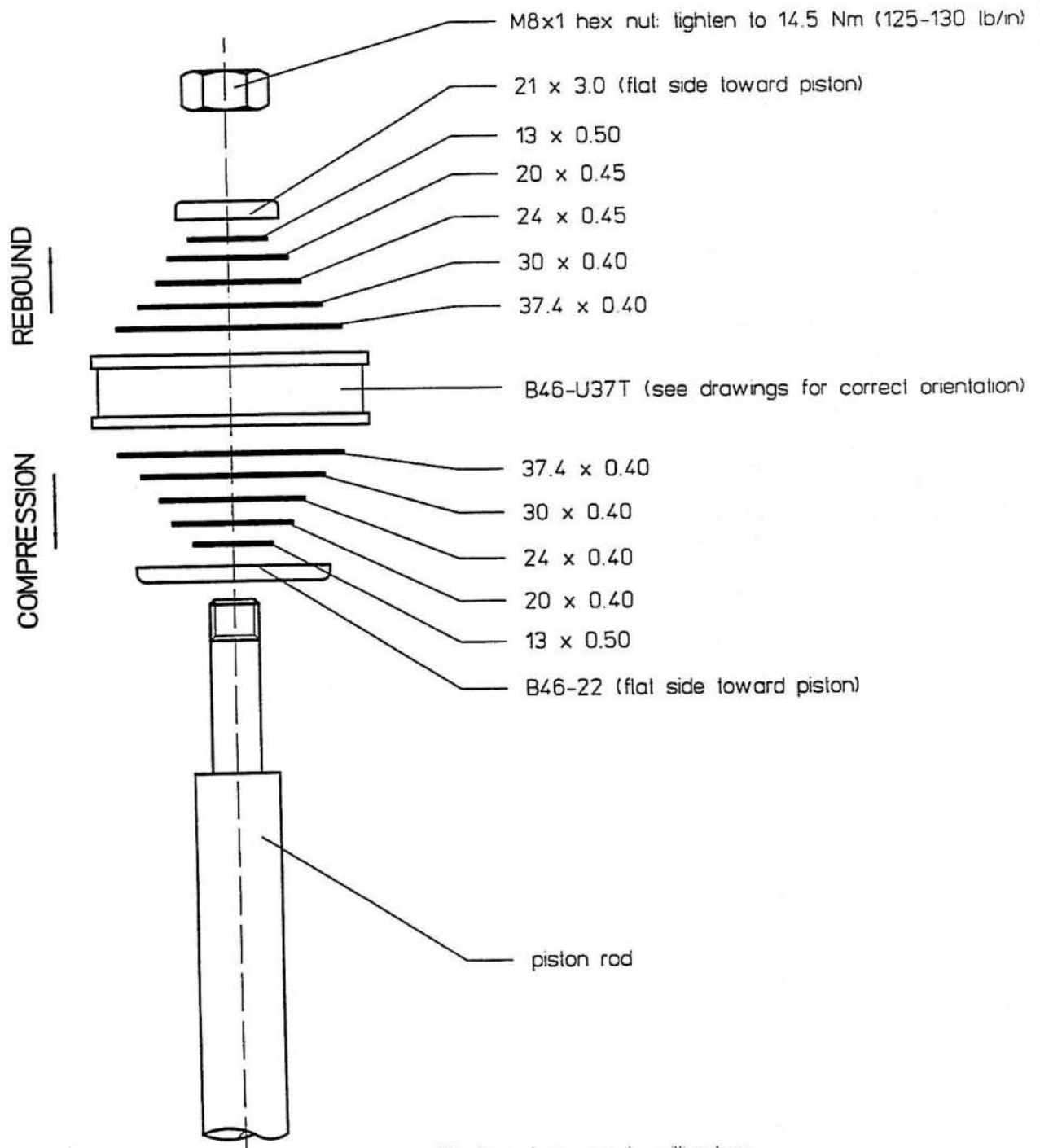

All disc sizes are in millimeters

example:

"30 x 0.30" is 30mm diameter, 0.30mm thick



VALVING: 390/180 (LINEAR)

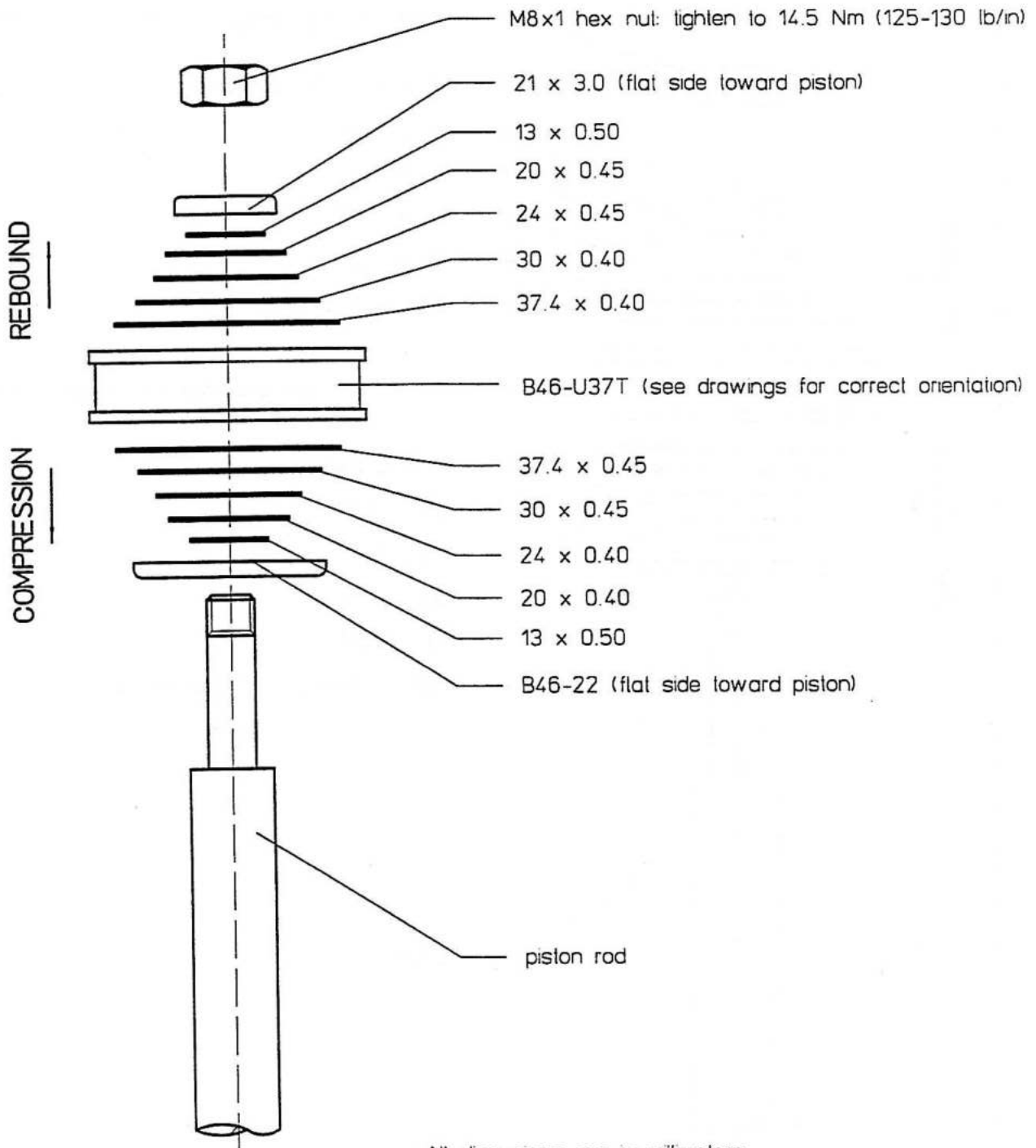

All disc sizes are in millimeters

example:

"30 x 0.30" is 30mm diameter, 0.30mm thick

VALVING: 400/160 (LINEAR)

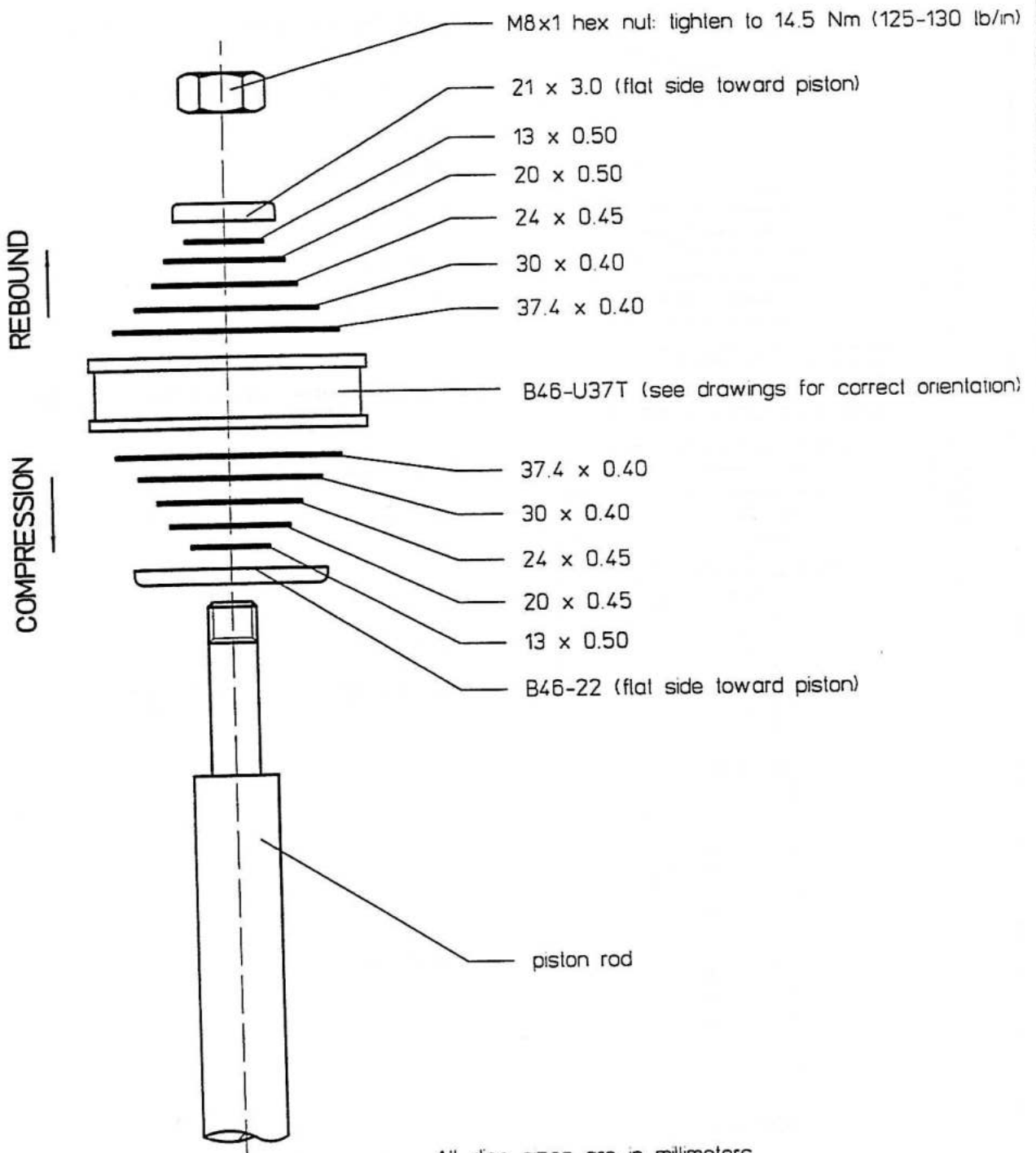

All disc sizes are in millimeters

example:

"30 x 0.30" is 30mm diameter, 0.30mm thick



VALVING: 420/160 (LINEAR)

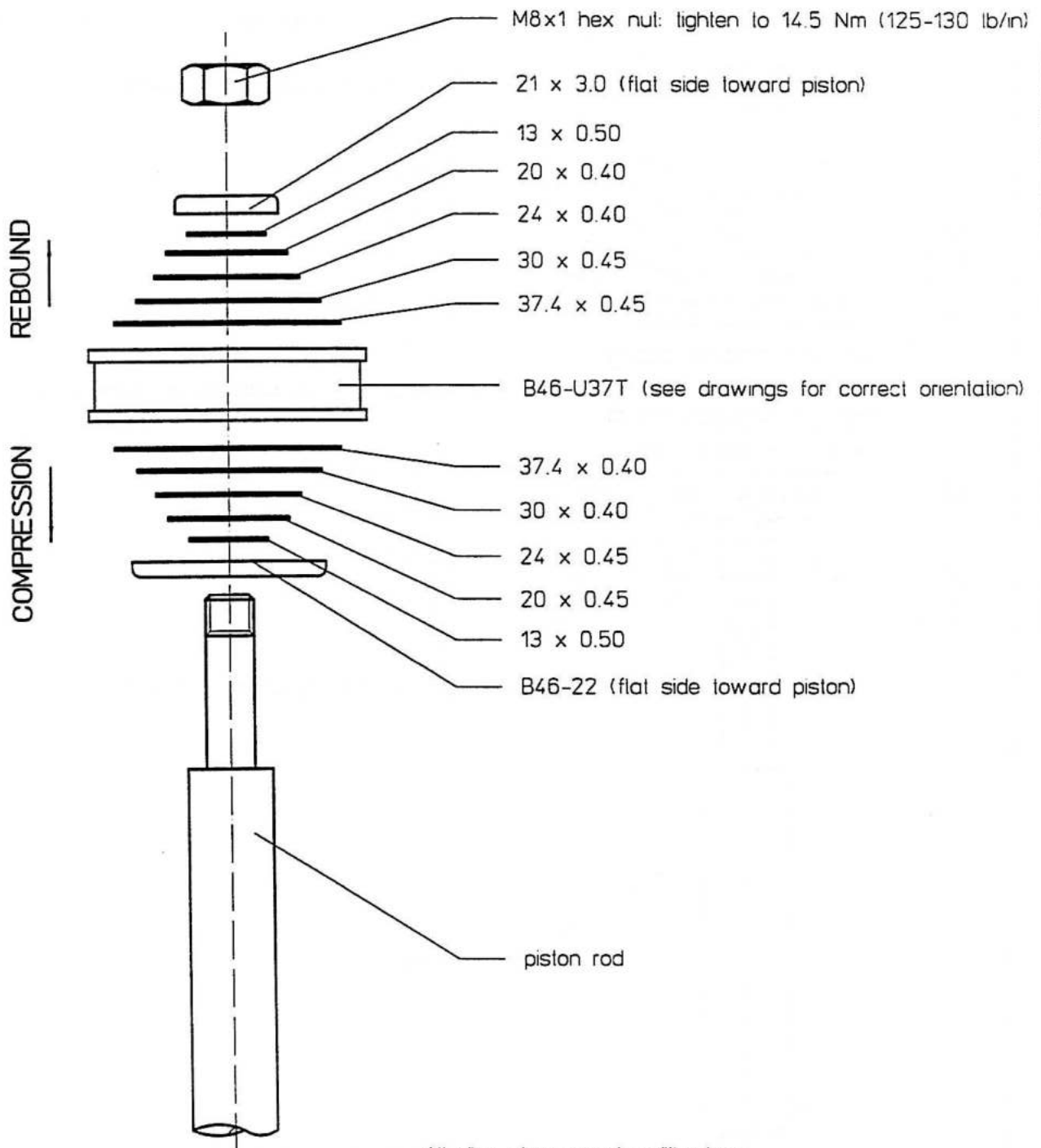

All disc sizes are in millimeters

example:

"30 x 0.30" is 30mm diameter, 0.30mm thick

VALVING: 420/180 (LINEAR)

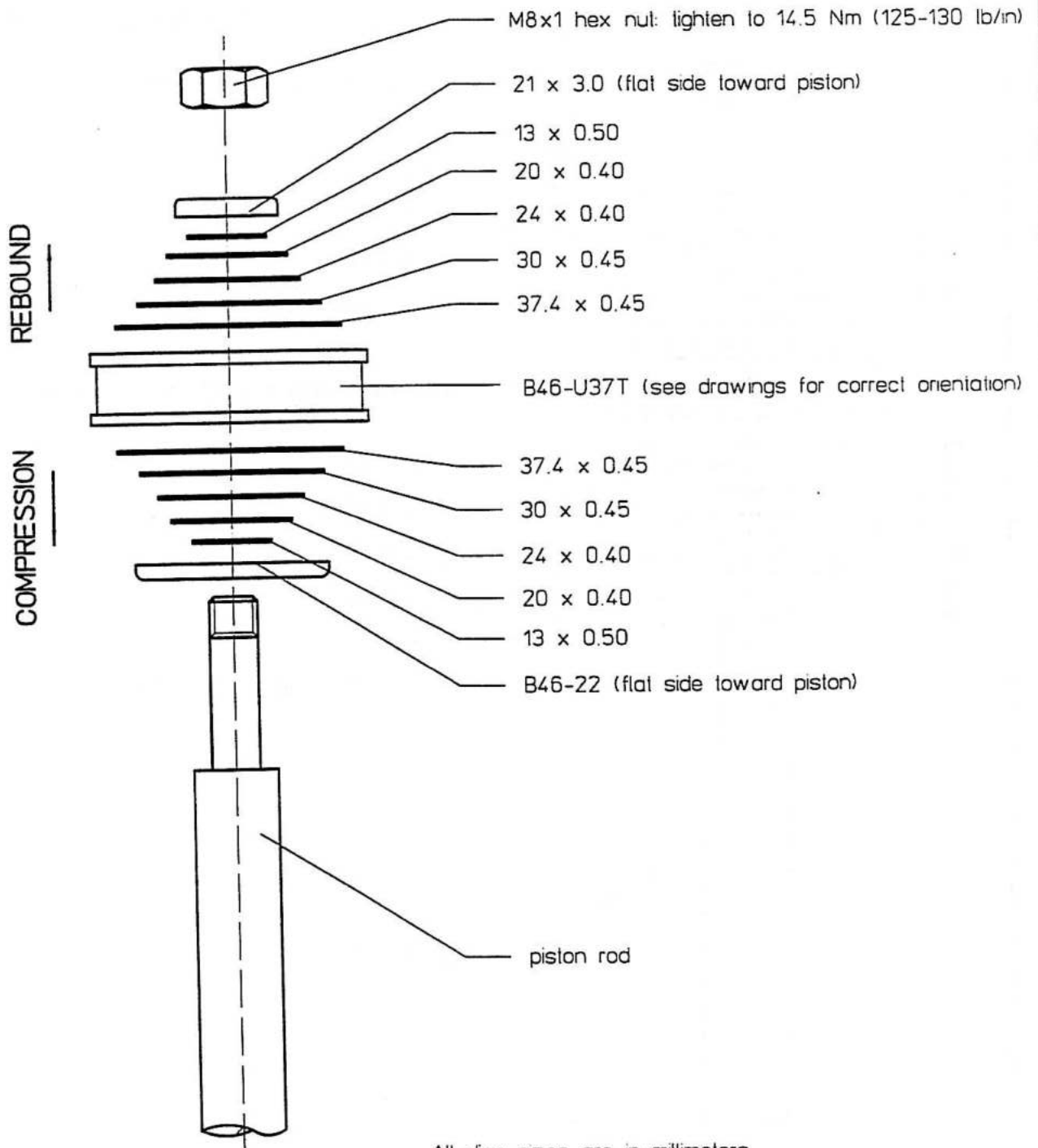

All disc sizes are in millimeters

example:

"30 x 0.30" is 30mm diameter, 0.30mm thick



VALVING: 420/205 (LINEAR)

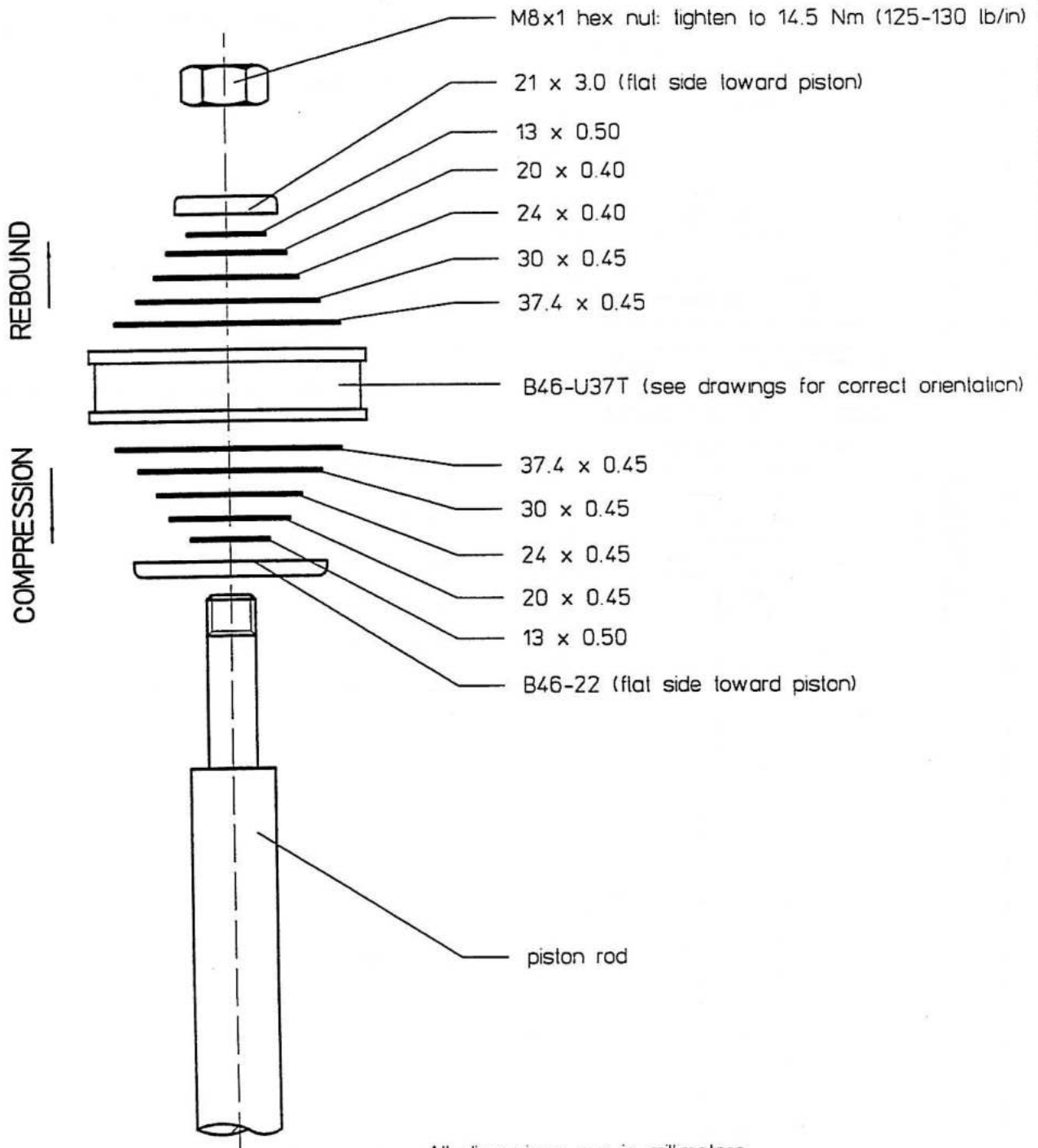

All disc sizes are in millimeters

example:

"30 x 0.30" is 30mm diameter, 0.30mm thick



VALVING: 480/160 (LINEAR)

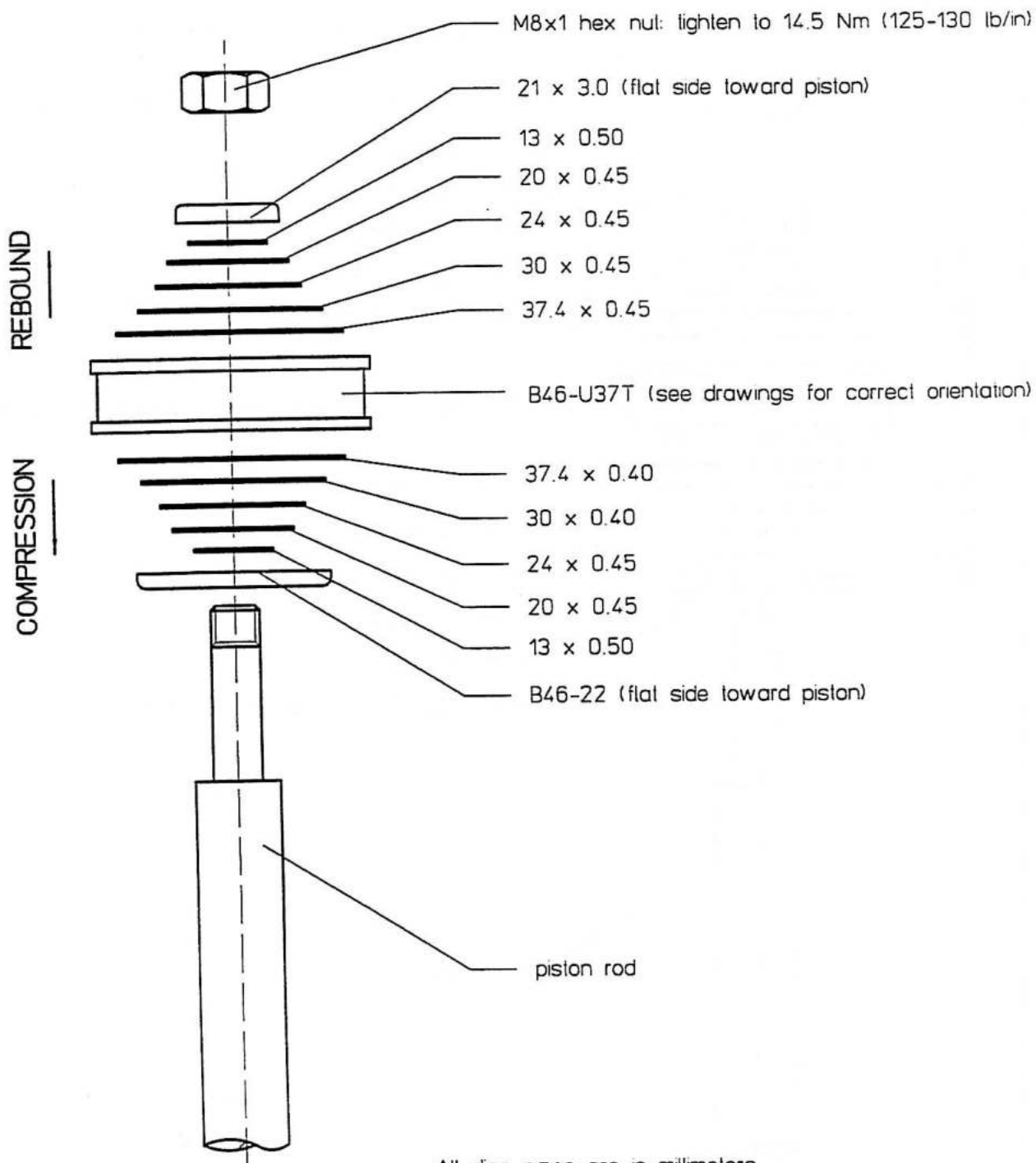

All disc sizes are in millimeters

example:

"30 x 0.30" is 30mm diameter, 0.30mm thick



VALVING: 480/180 (LINEAR)

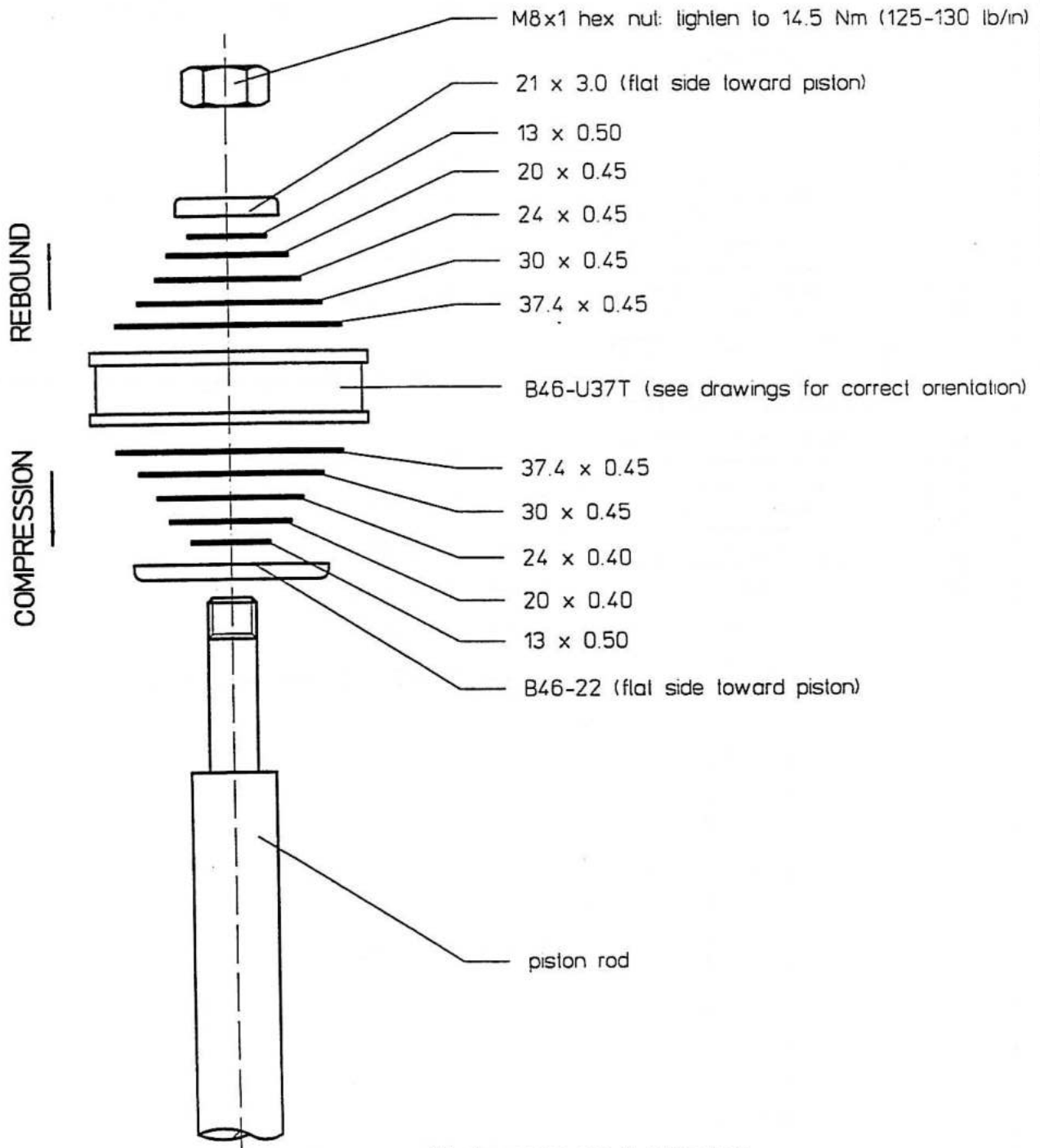

All disc sizes are in millimeters

example:

30 x 0.30 is 30mm diameter, 0.30mm thick



VALVING: 480/205 (LINEAR)

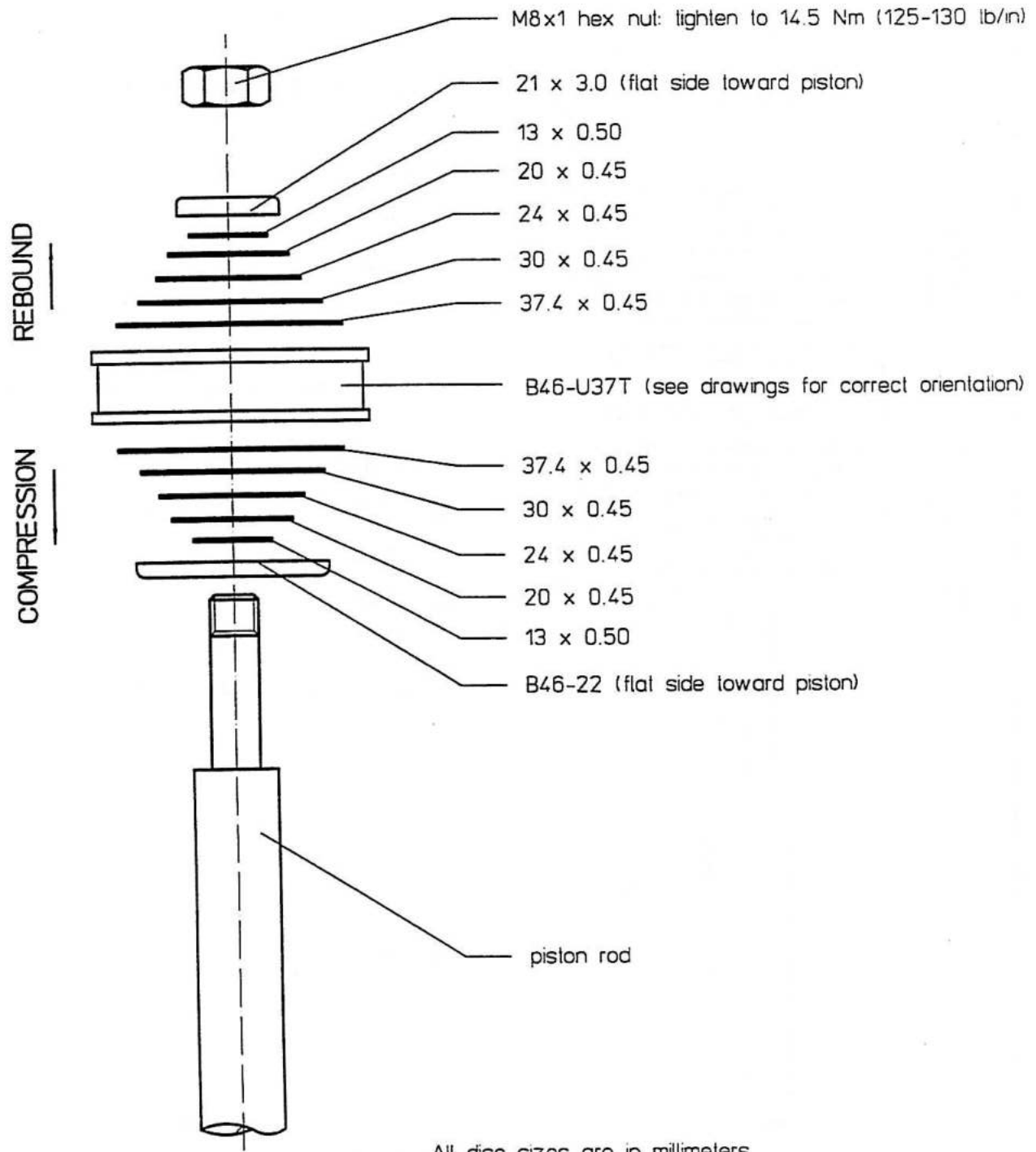

All disc sizes are in millimeters

example:

"30 x 0.30" is 30mm diameter, 0.30mm thick



VALVING: 520/160 (LINEAR)

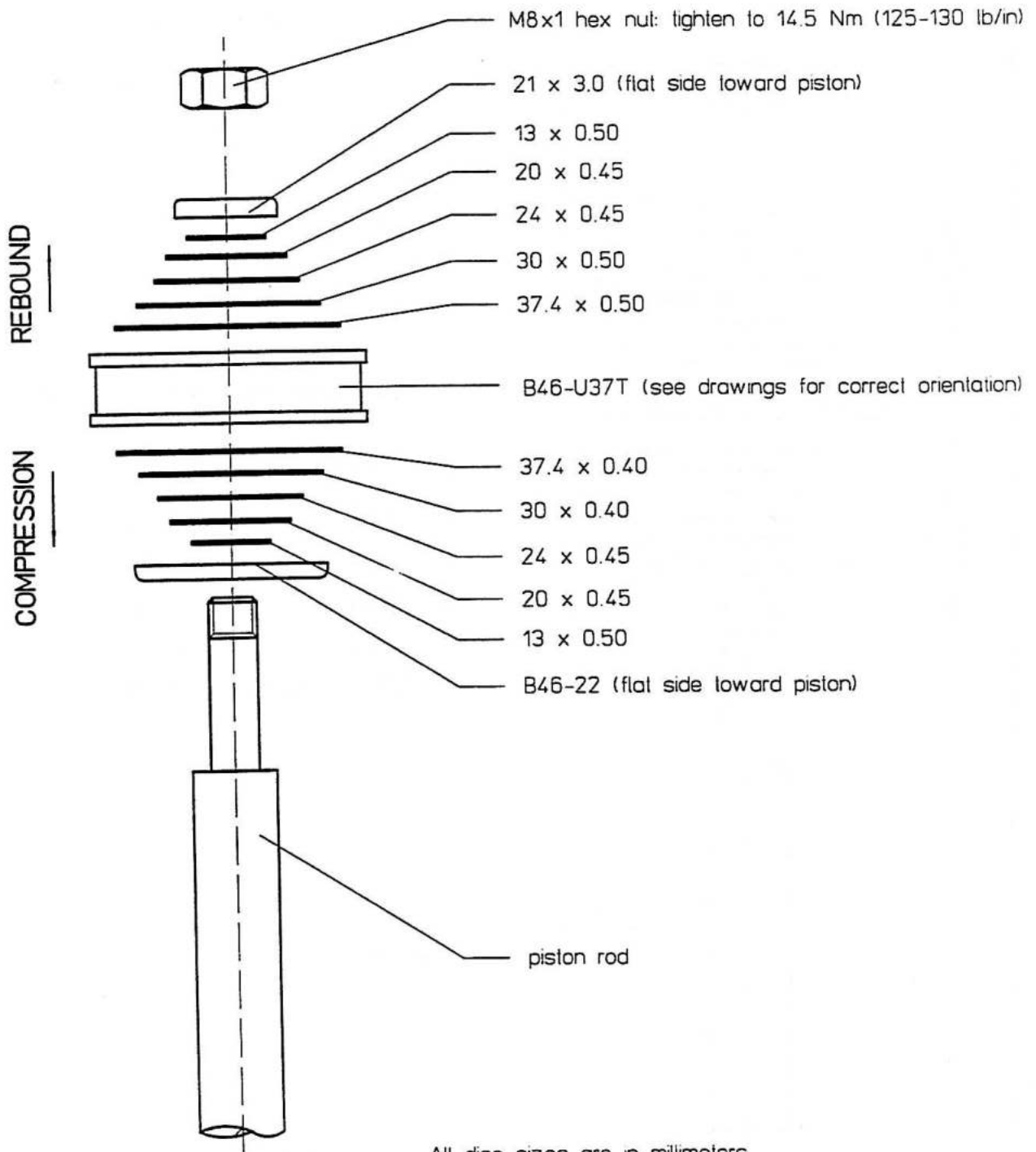

All disc sizes are in millimeters

example:

"30 x 0.30" is 30mm diameter, 0.30mm thick



VALVING: 520/180 (LINEAR)

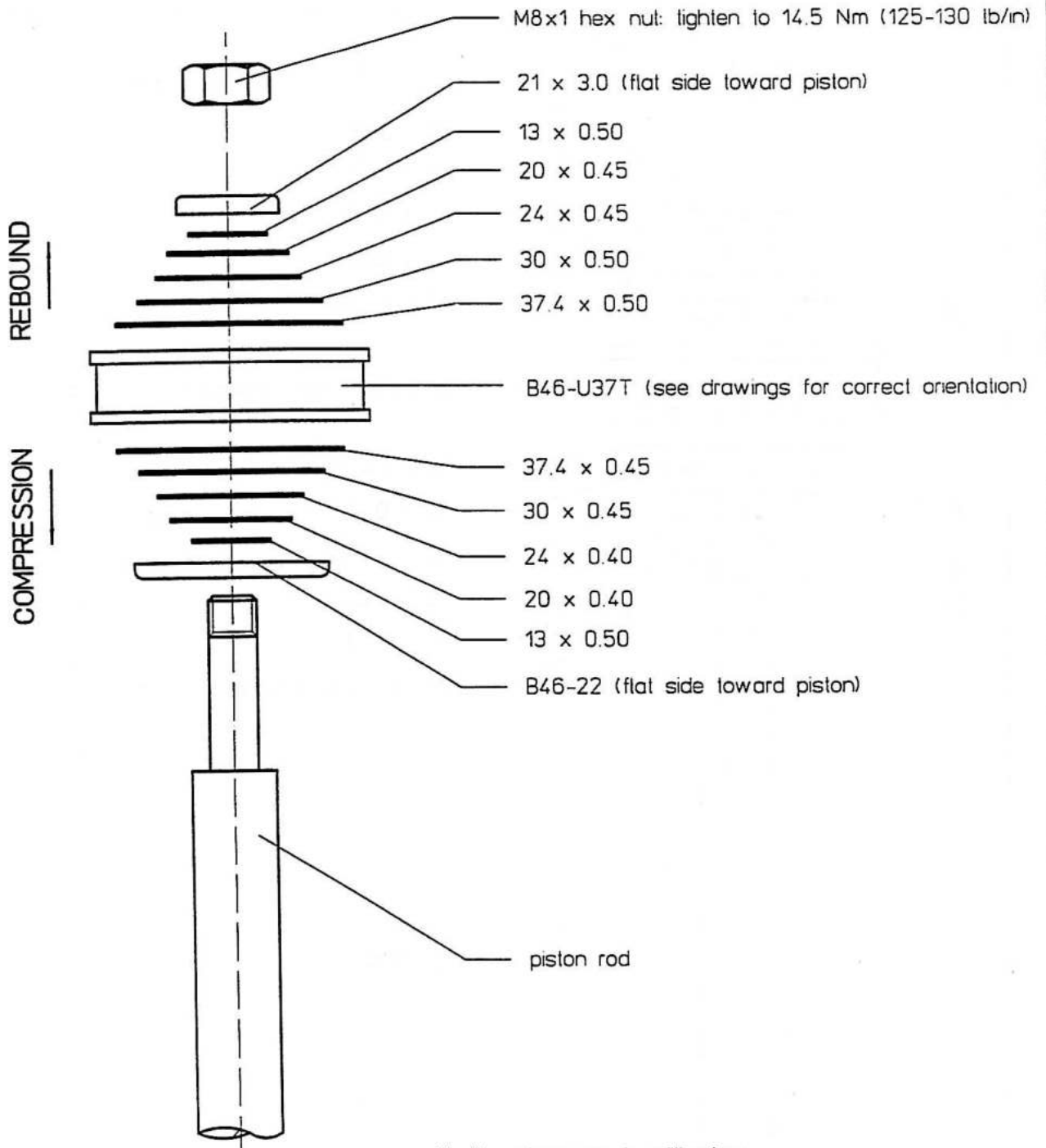

All disc sizes are in millimeters

example:

"30 x 0.30" is 30mm diameter, 0.30mm thick



VALVING: 520/205 (LINEAR)

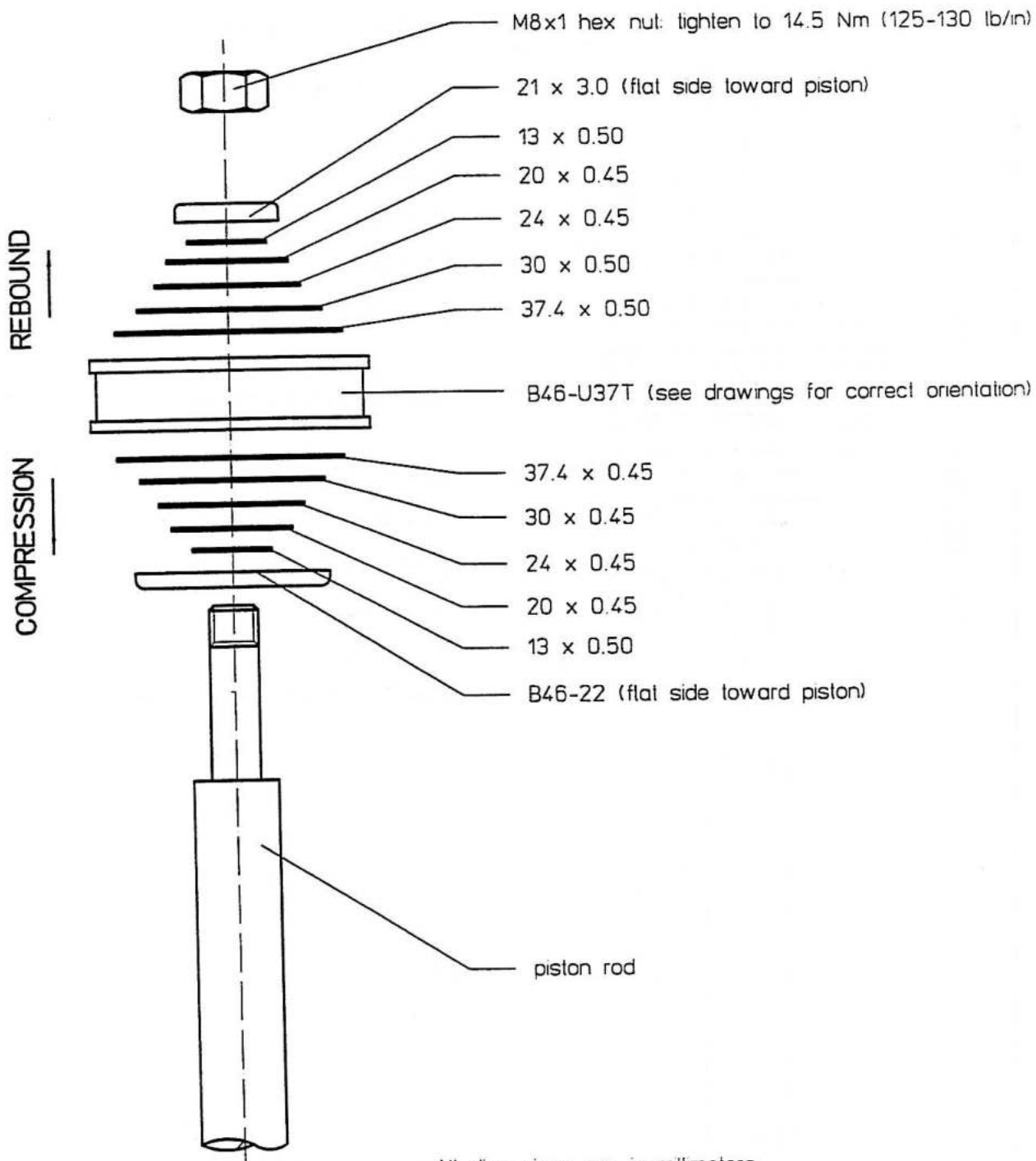

All disc sizes are in millimeters

example:

"30 x 0.30" is 30mm diameter, 0.30mm thick

VALVING: 588/180 (LINEAR)

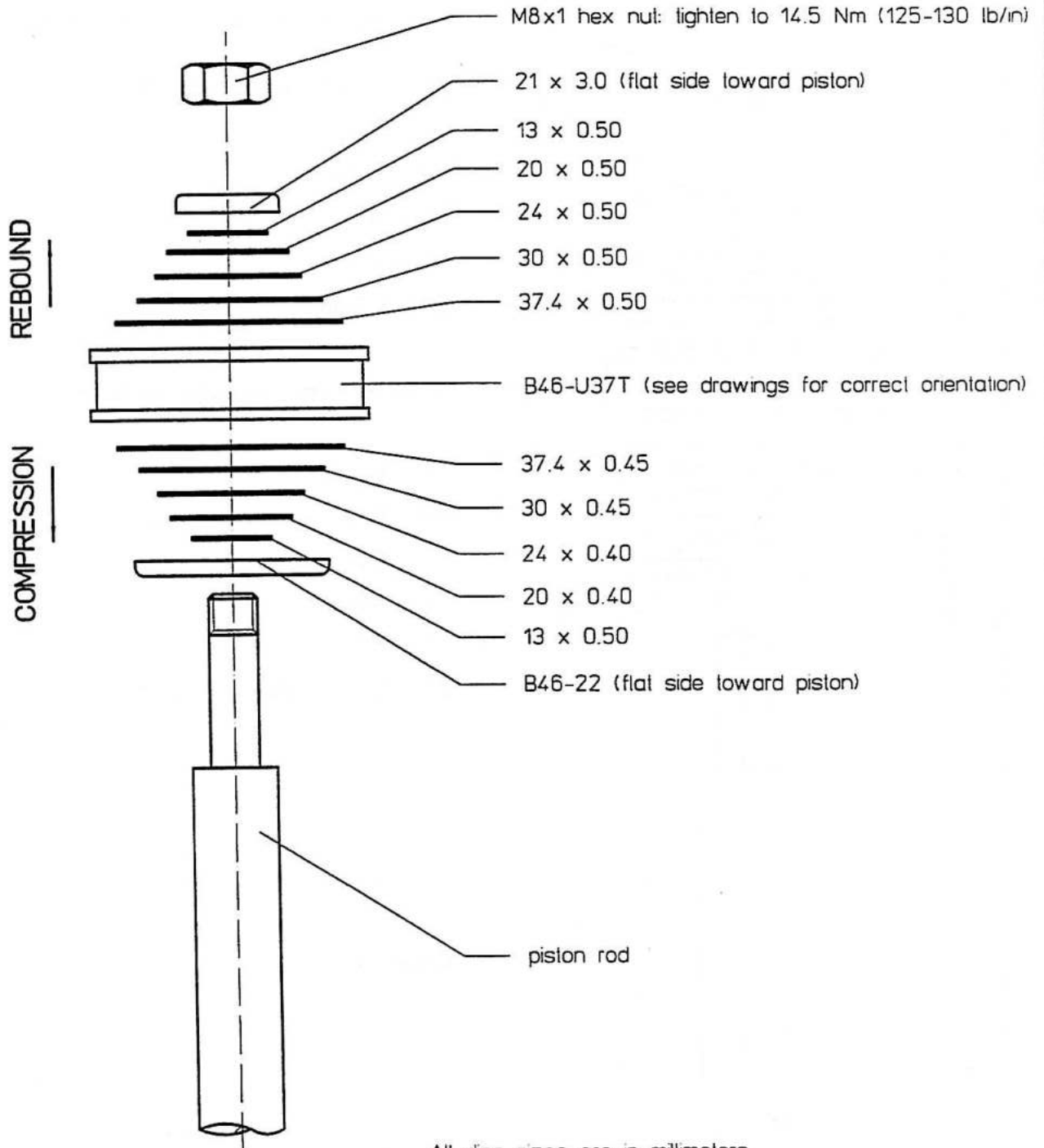

All disc sizes are in millimeters

example:

30 x 0.30 is 30mm diameter, 0.30mm thick



VALVING: 588/220 (LINEAR)

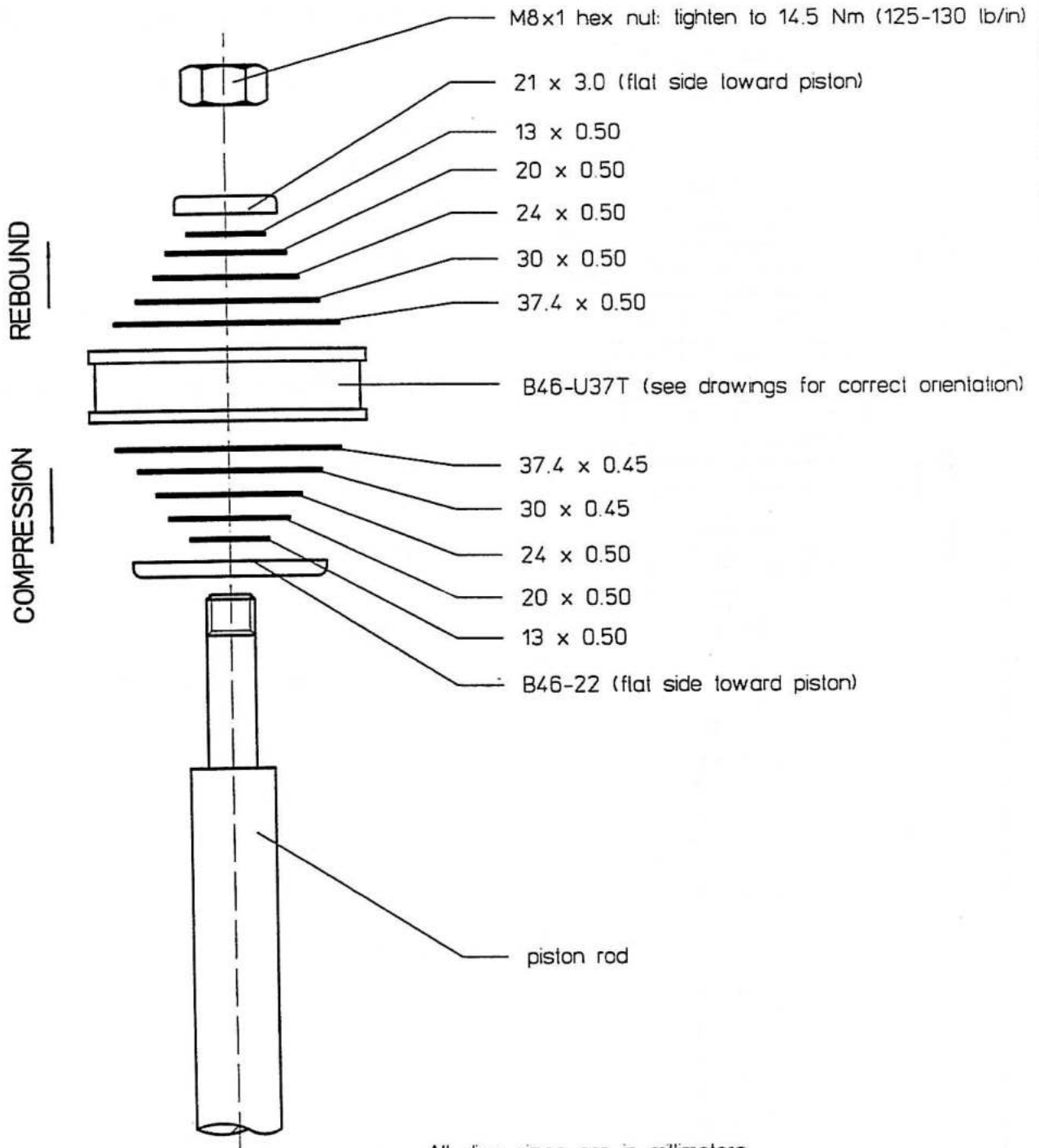

All disc sizes are in millimeters

example:

30 x 0.30 is 30mm diameter, 0.30mm thick



VALVING: 688/180 (LINEAR)

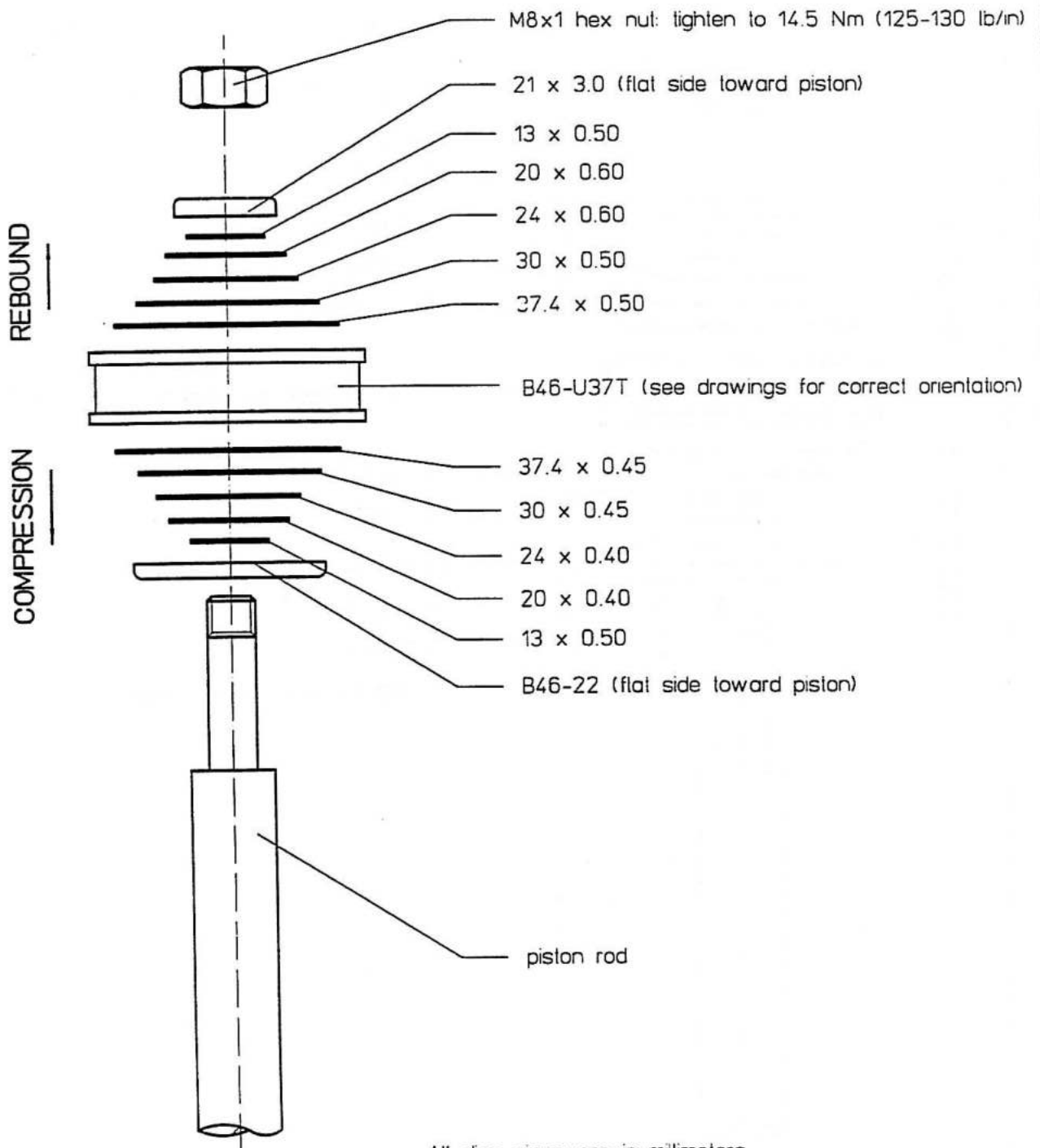

All disc sizes are in millimeters

example:

"30 x 0.30" is 30mm diameter, 0.30mm thick



VALVING: 688/220 (LINEAR)

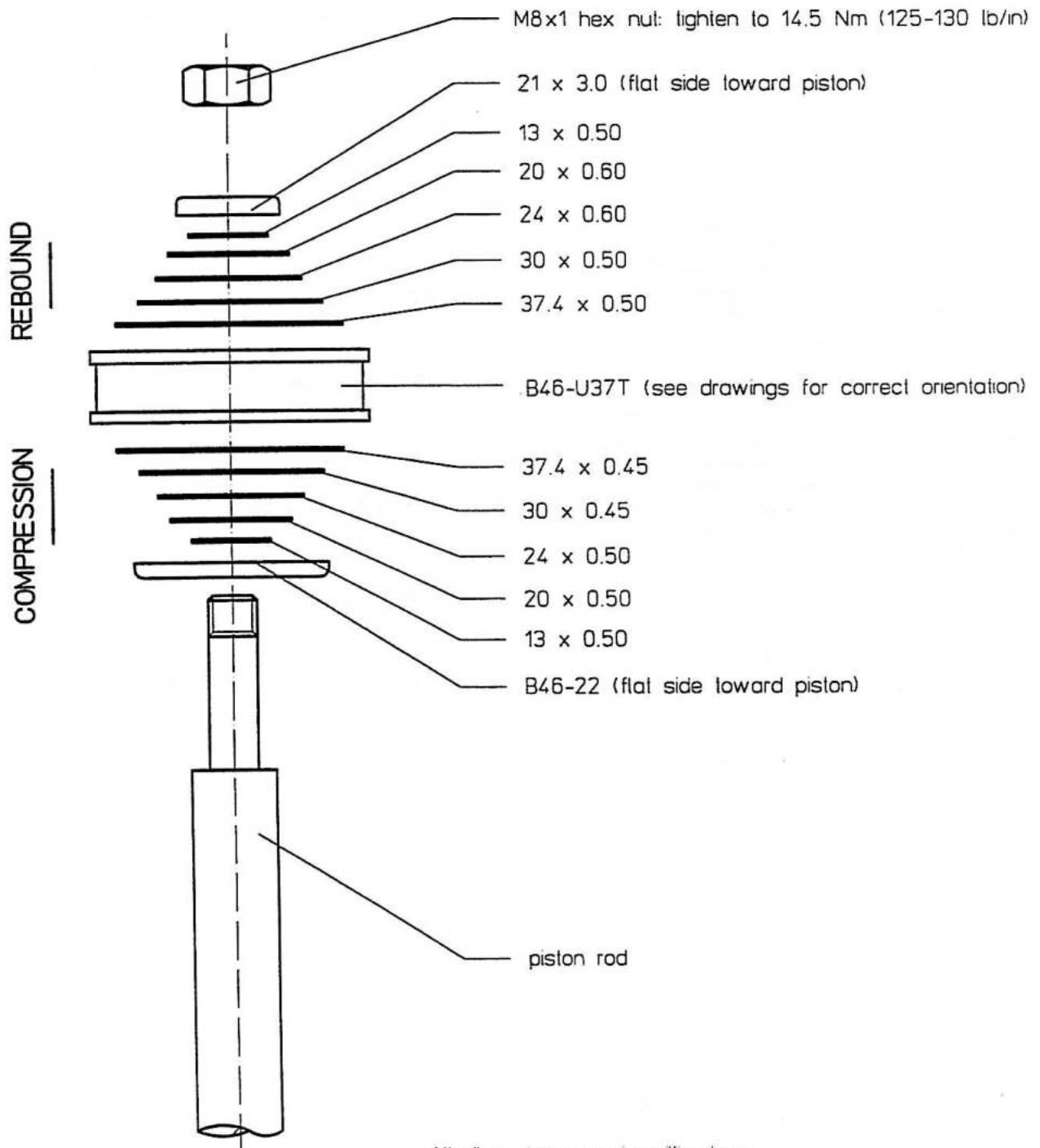

All disc sizes are in millimeters

example:

30 x 0.30 is 30mm diameter, 0.30mm thick

VALVING: 275-110D (DIGRESSIVE)

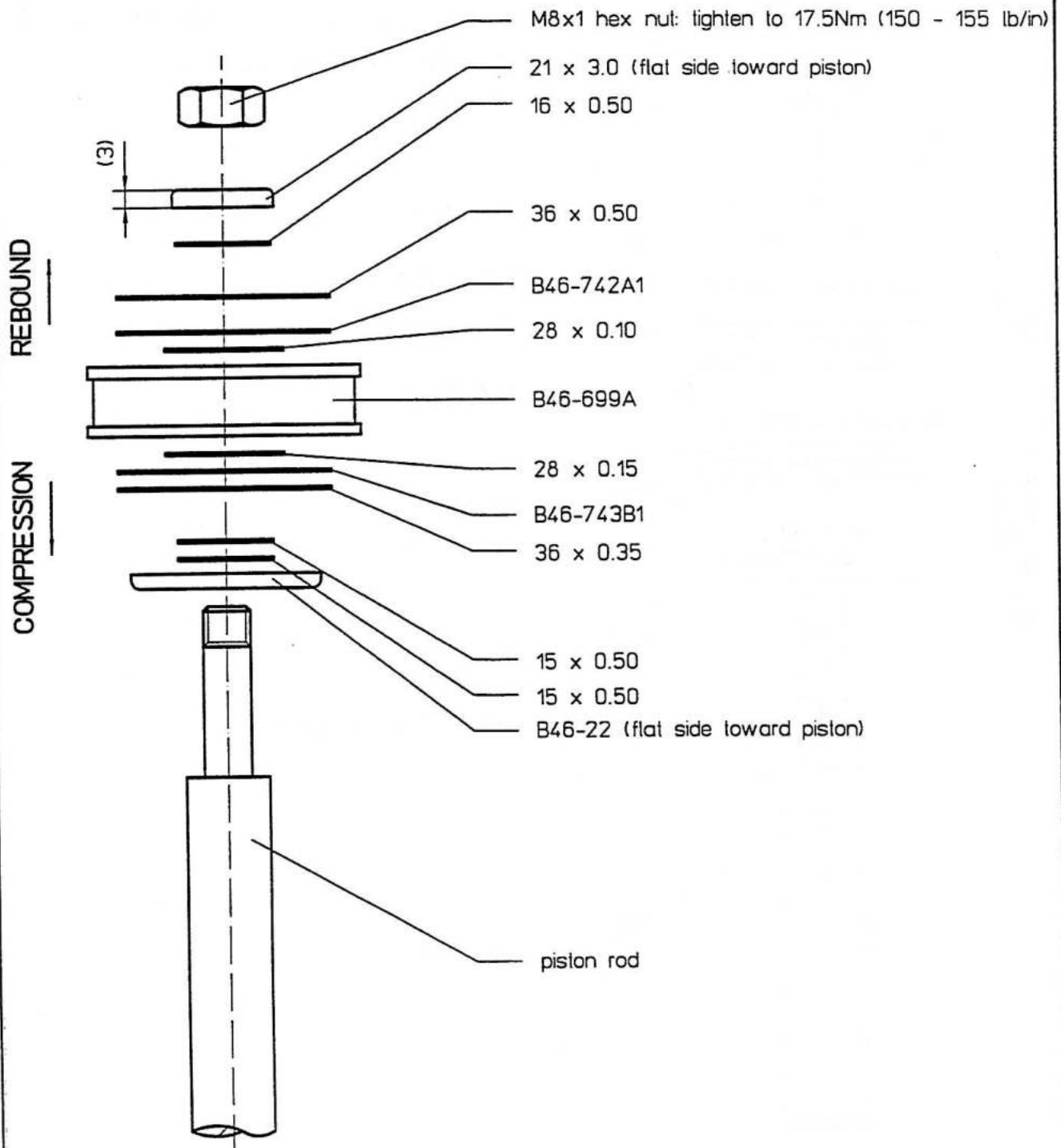

All disc sizes are in millimeters

example:

"36 x 0.50" is 36mm diameter, 0.50mm thick



VALVING: 290-130D (DIGRESSIVE)

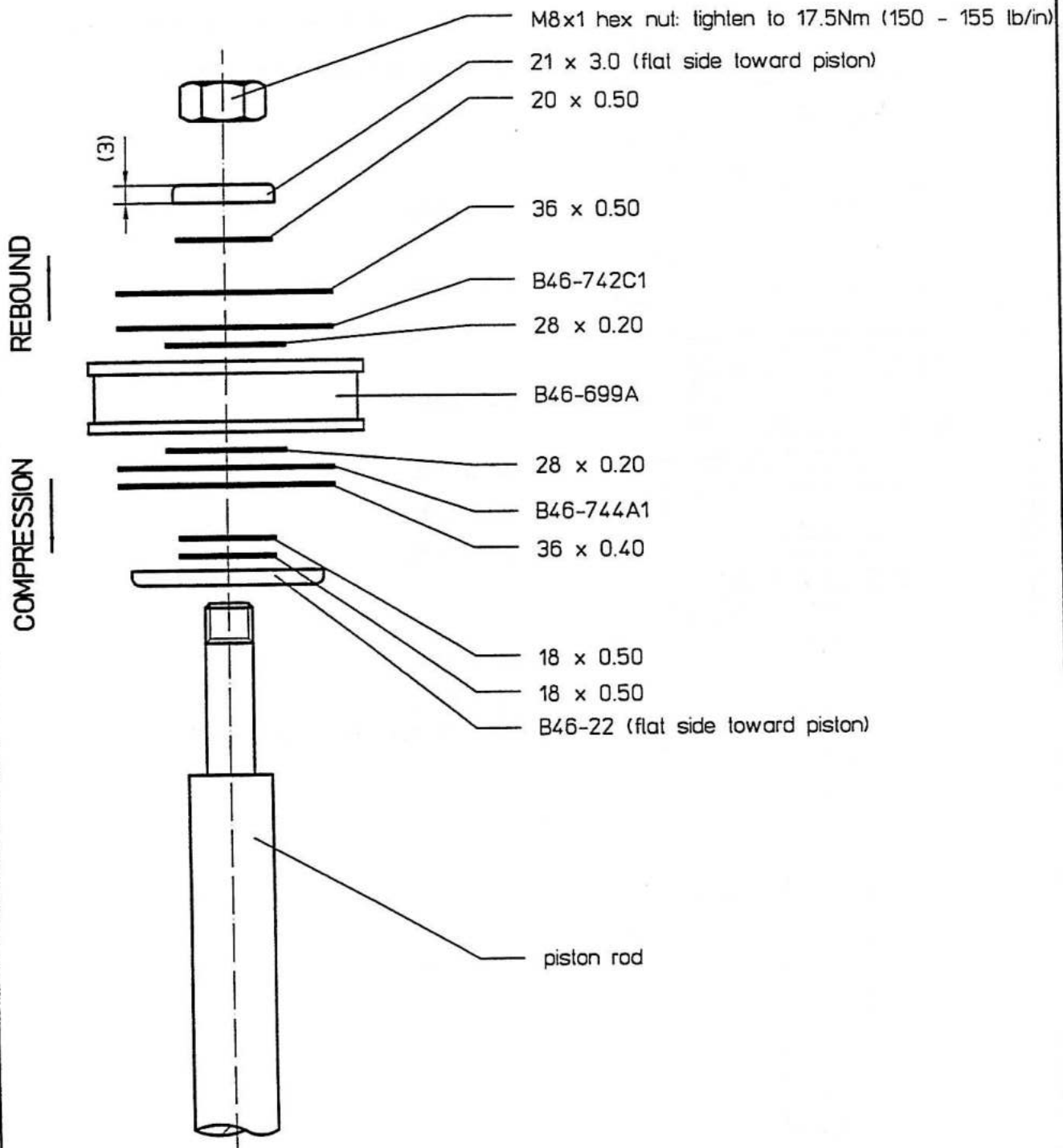

All disc sizes are in millimeters

example:

36 x 0.50 is 36mm diameter, 0.50mm thick



VALVING: 300-100D (DIGRESSIVE)

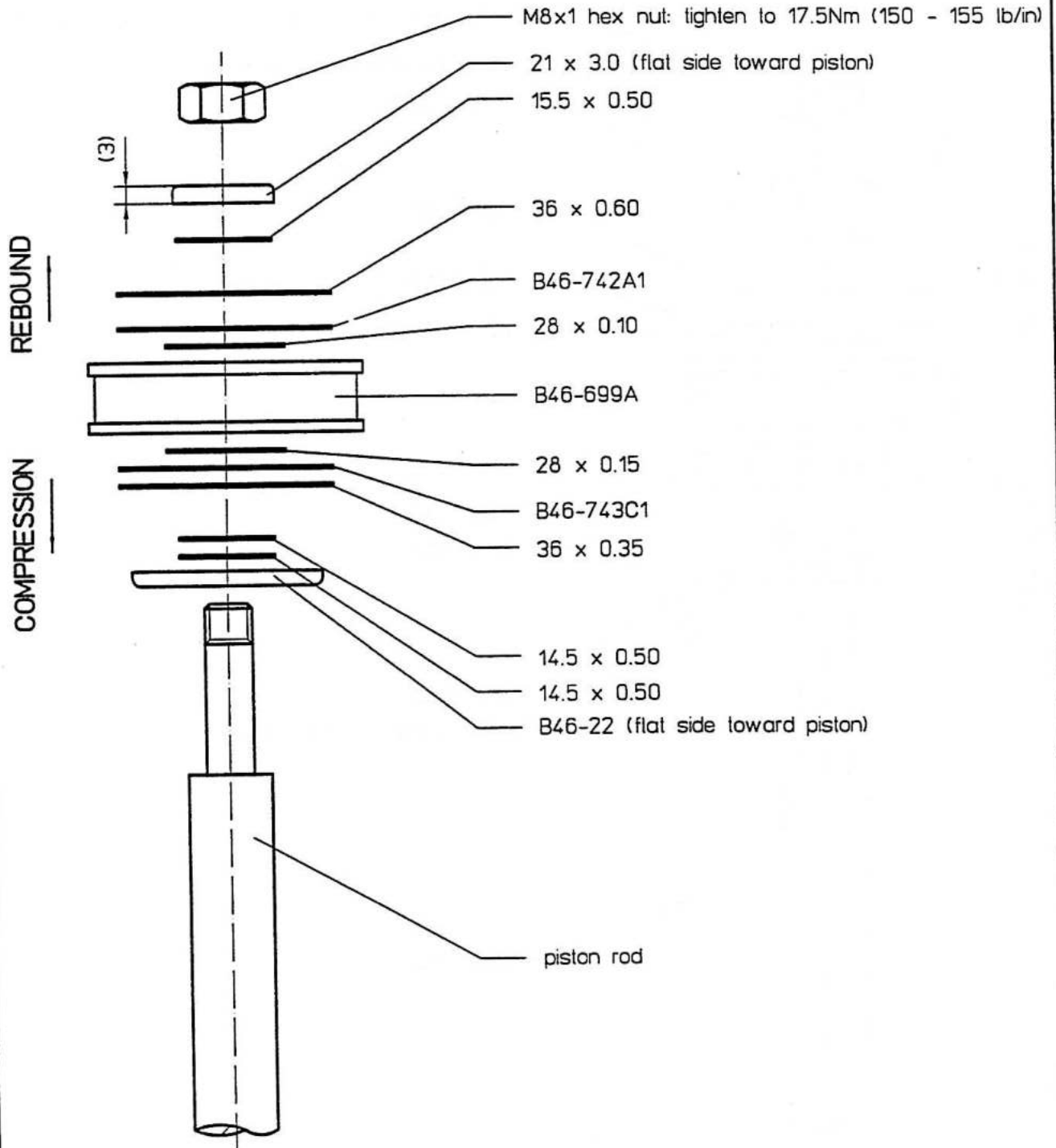

All disc sizes are in millimeters

example:

36 x 0.50 is 36mm diameter, 0.50mm thick



VALVING: 325-110D (DIGRESSIVE)

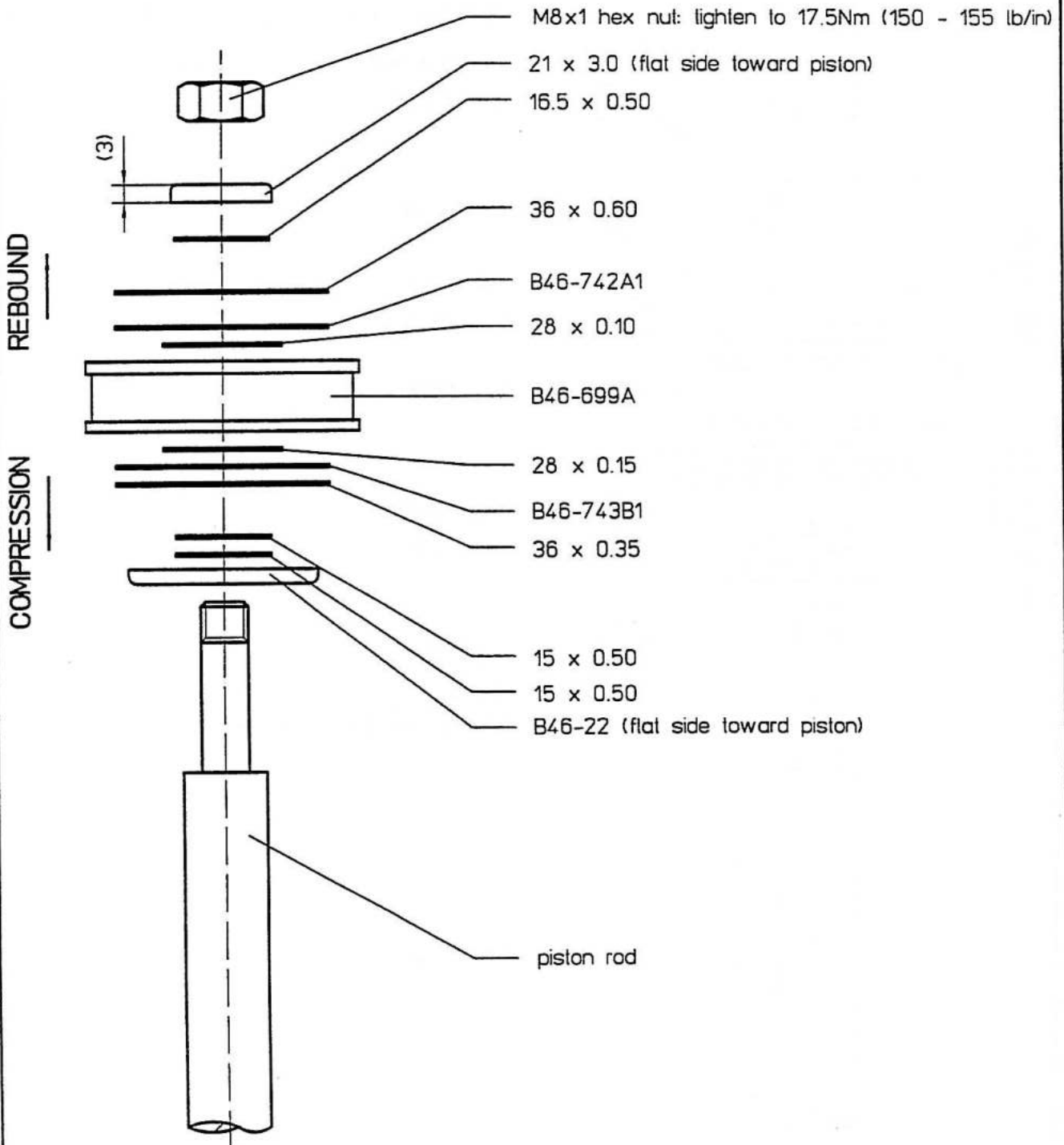

All disc sizes are in millimeters

example:

'36 x 0.50' is 36mm diameter, 0.50mm thick



VALVING: 325-125D (DIGRESSIVE)

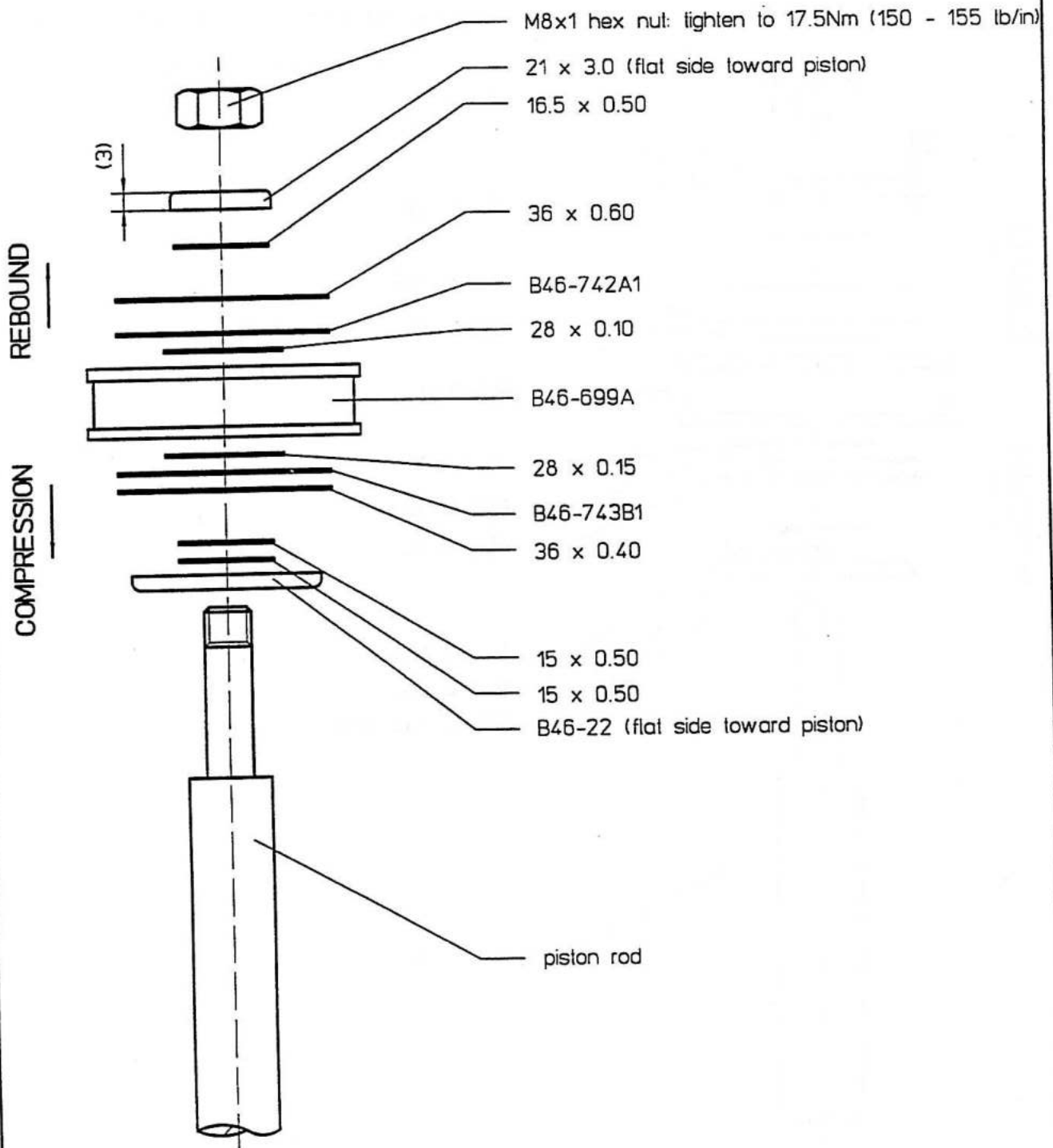

All disc sizes are in millimeters

example:

36 x 0.50 is 36mm diameter, 0.50mm thick



VALVING: 345-135D (DIGRESSIVE)

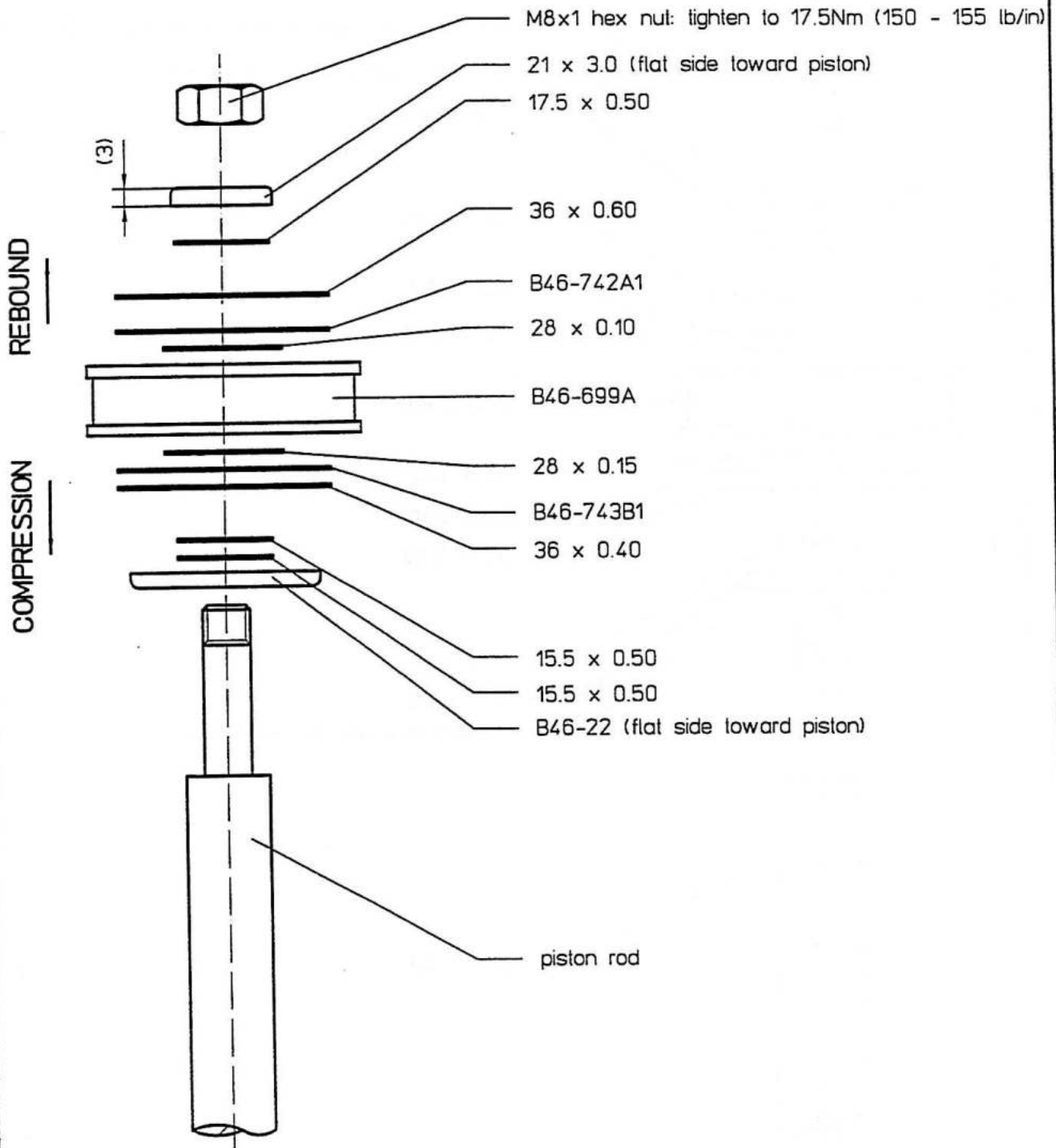

All disc sizes are in millimeters

example:

'36 x 0.50' is 36mm diameter, 0.50mm thick



VALVING: 420-140D (DIGRESSIVE)

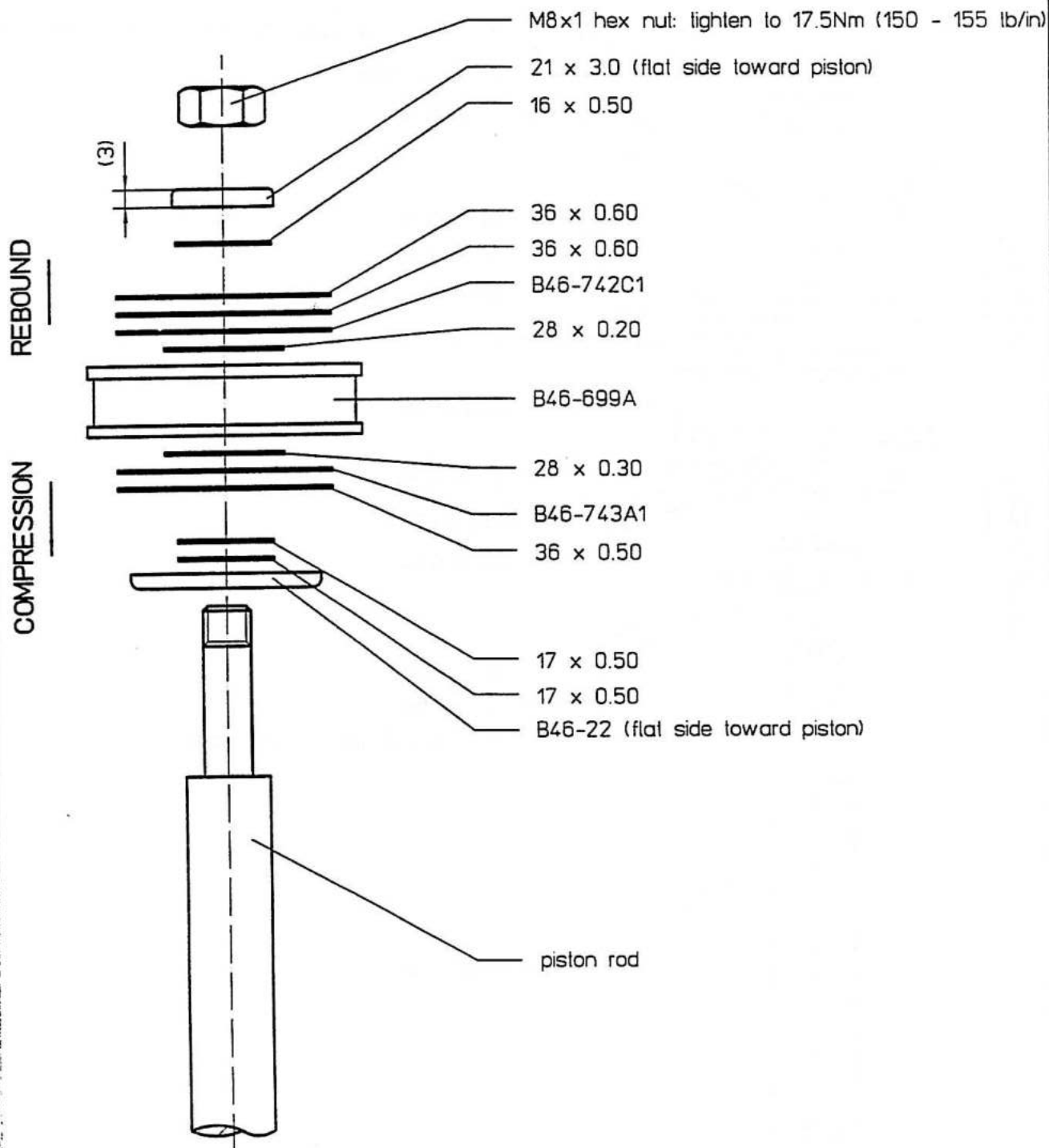

All disc sizes are in millimeters

example:

36 x 0.50 is 36mm diameter, 0.50mm thick



VALVING: 460-140D (DIGRESSIVE)

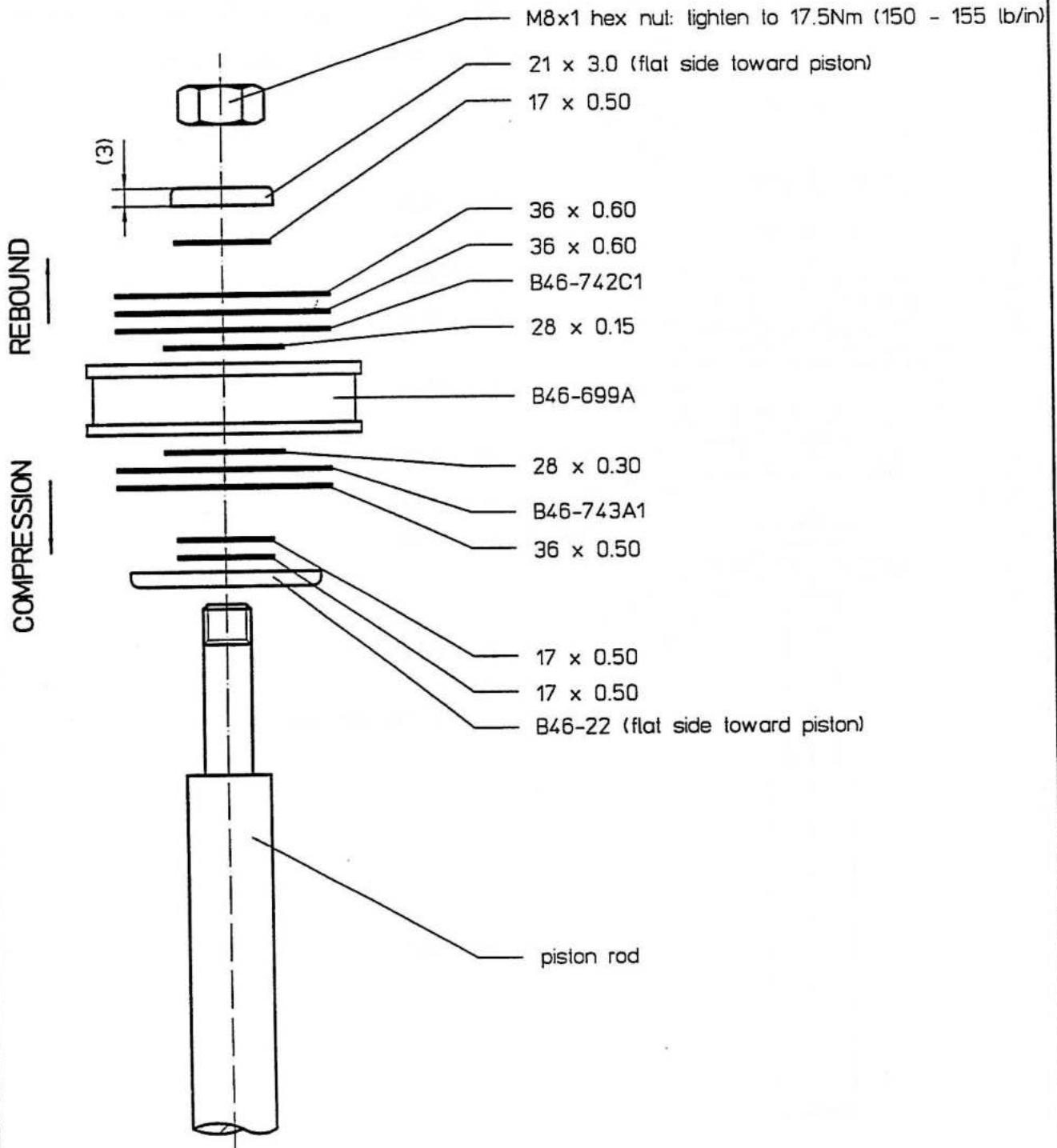

All disc sizes are in millimeters

example:

36 x 0.50 is 36mm diameter, 0.50mm thick

VALVING: 480-160D (DIGRESSIVE)

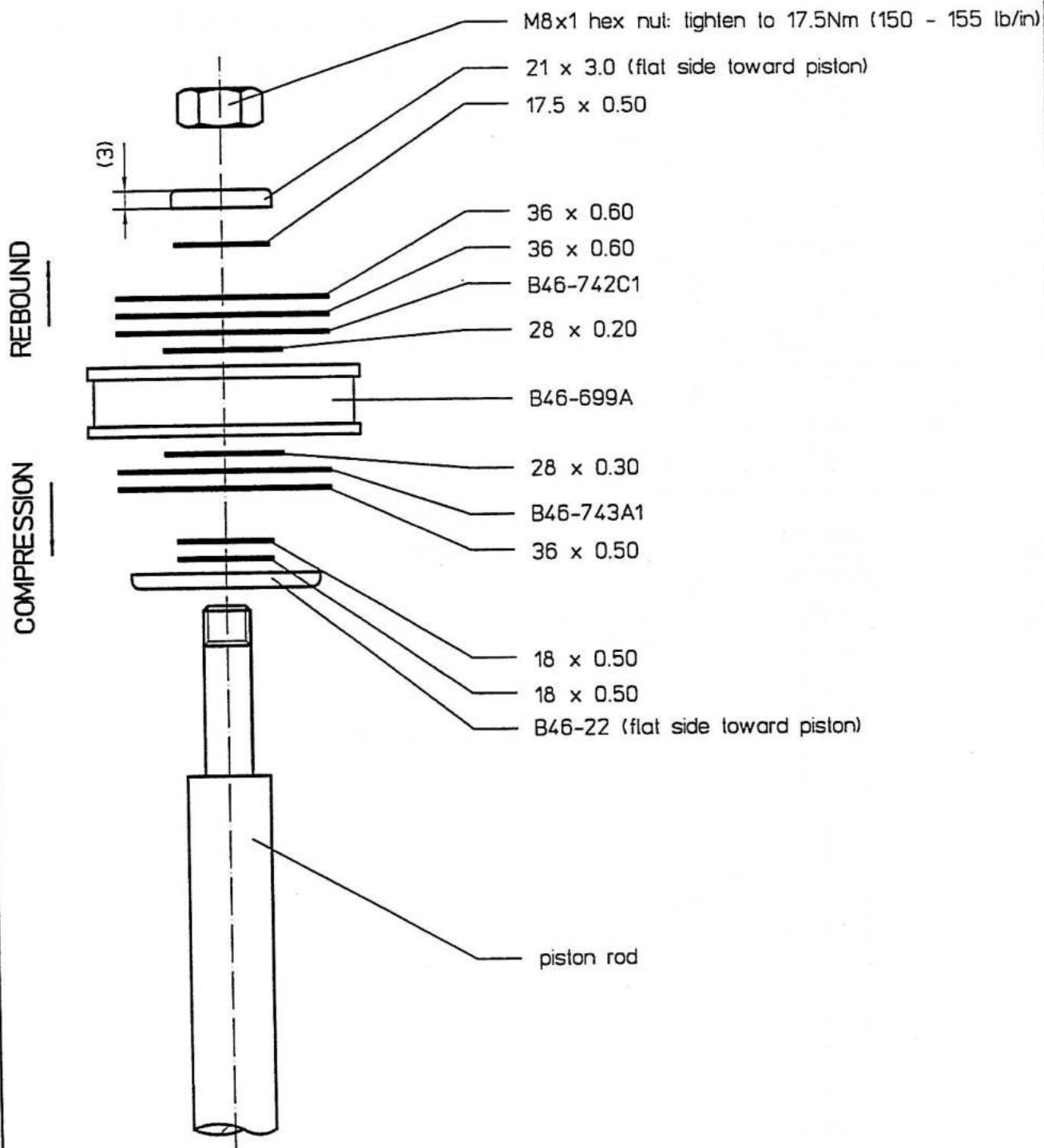

All disc sizes are in millimeters

example:

'36 x 0.50' is 36mm diameter, 0.50mm thick



VALVING: 520-160D (DIGRESSIVE)

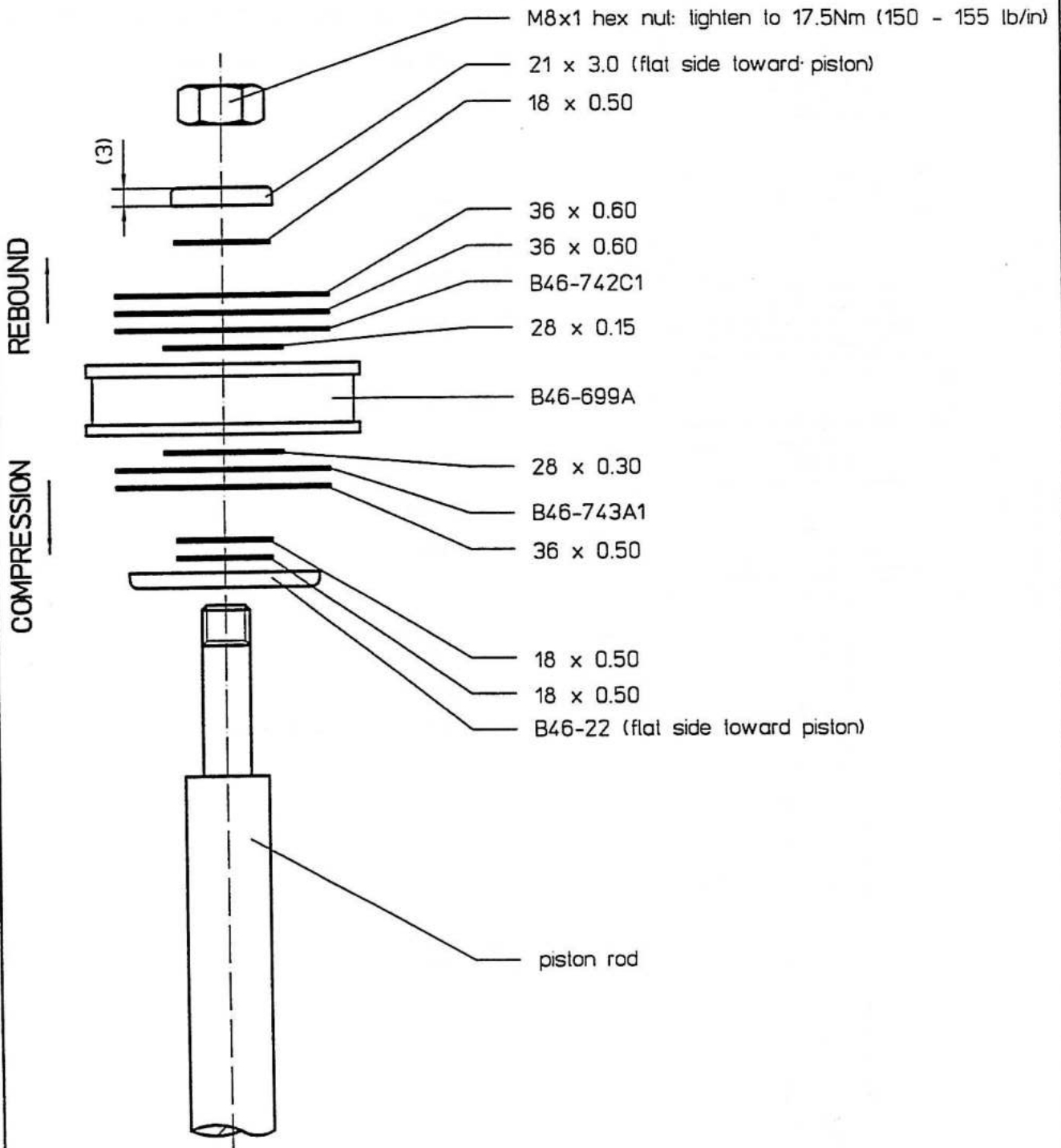

All disc sizes are in millimeters

example:

"36 x 0.50" is 36mm diameter, 0.50mm thick



VALVING: 560-160D (DIGRESSIVE)

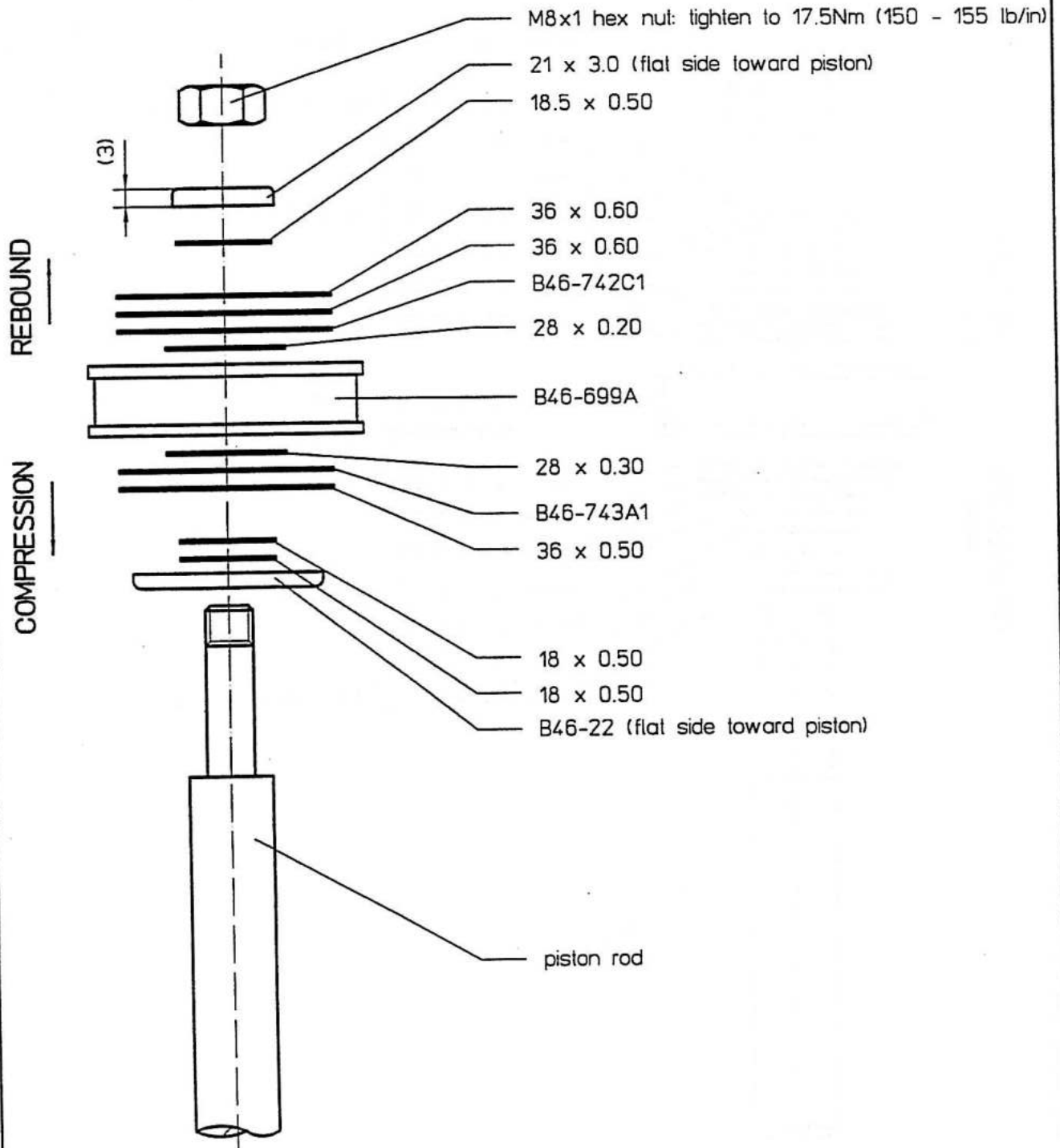

All disc sizes are in millimeters

example:

36 x 0.50 is 36mm diameter, 0.50mm thick



VALVING: GNA1

540-170 (LINEAR)

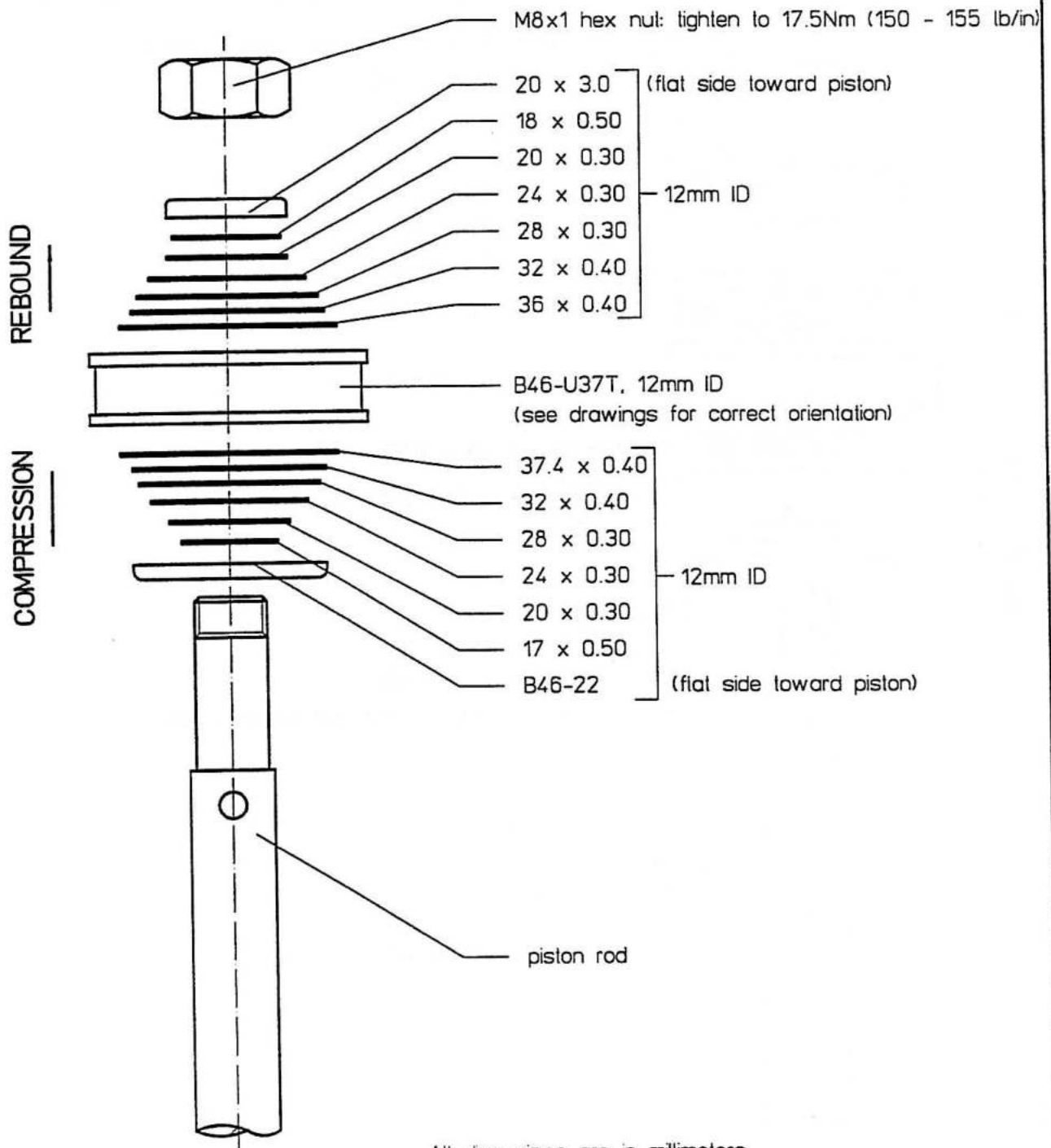

All disc sizes are in millimeters

example:

32 x 0.30 is 32mm diameter, 0.30mm thick

VALVING: GNA2
648-204 (LINEAR)

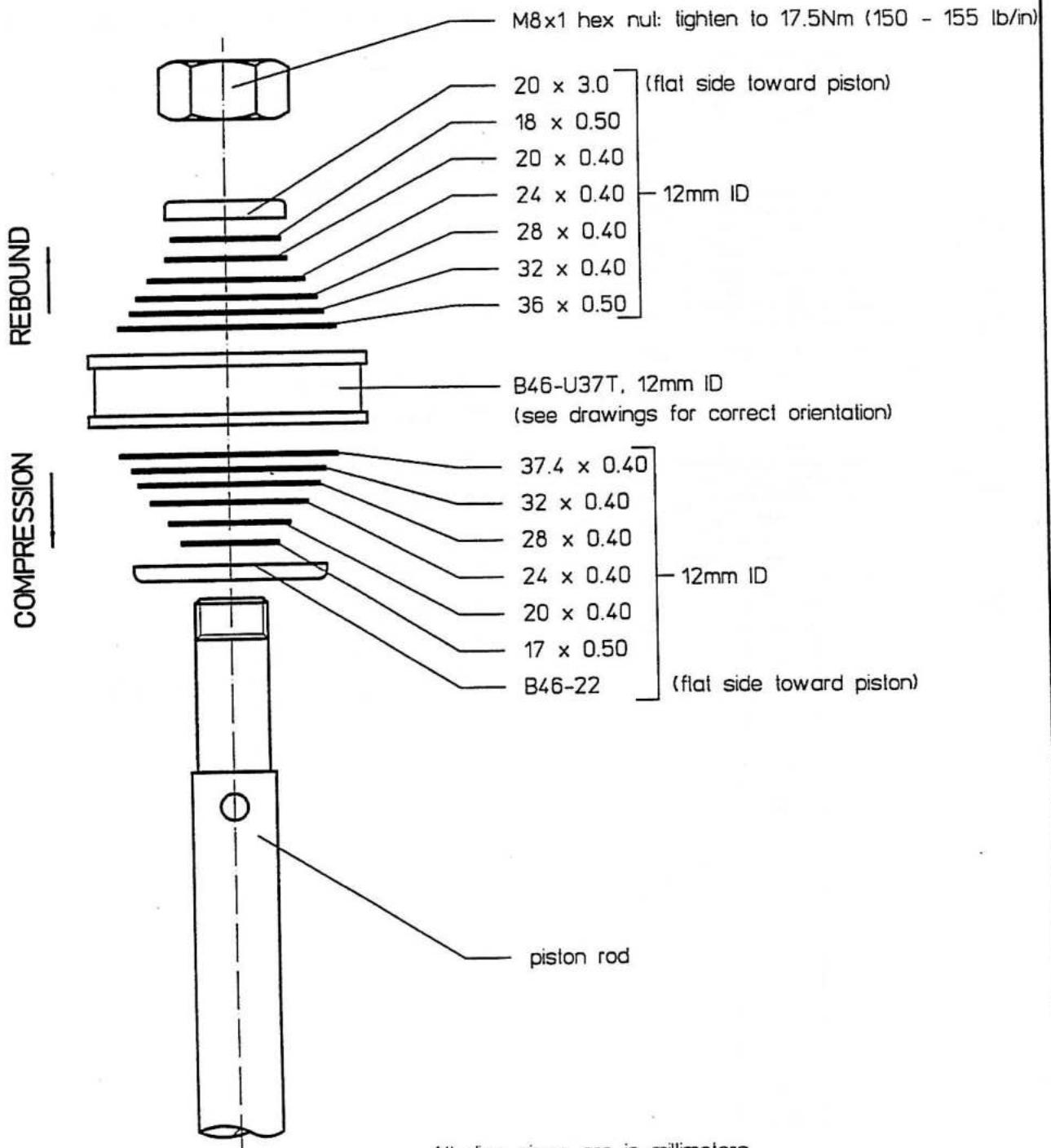

All disc sizes are in millimeters

example:

'32 x 0.30' is 32mm diameter, 0.30mm thick



VALVING: GNA3
270-104 (LINEAR)

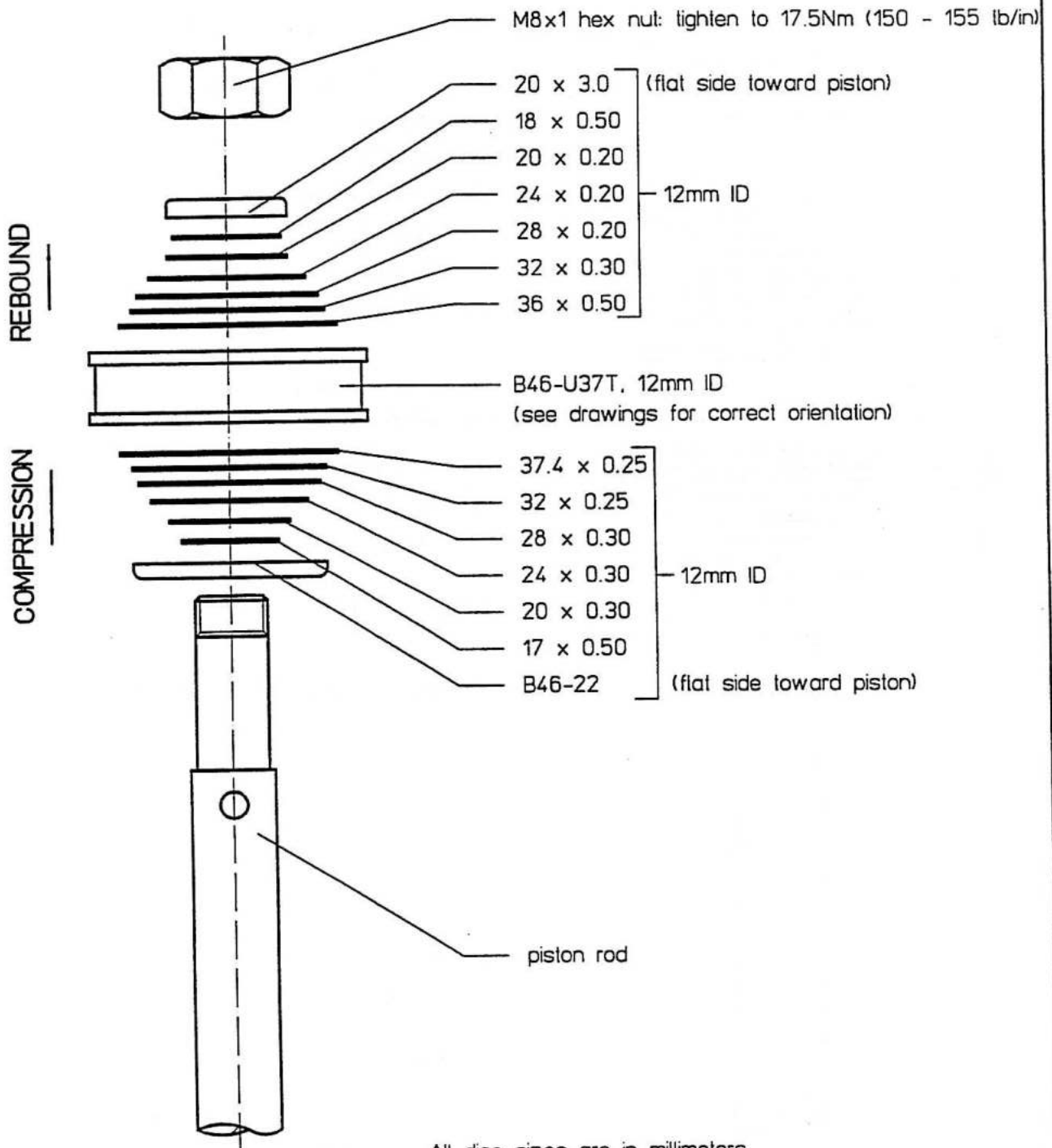

All disc sizes are in millimeters

example:

32 x 0.30 is 32mm diameter, 0.30mm thick



VALVING: GNA4
554-147 (LINEAR)

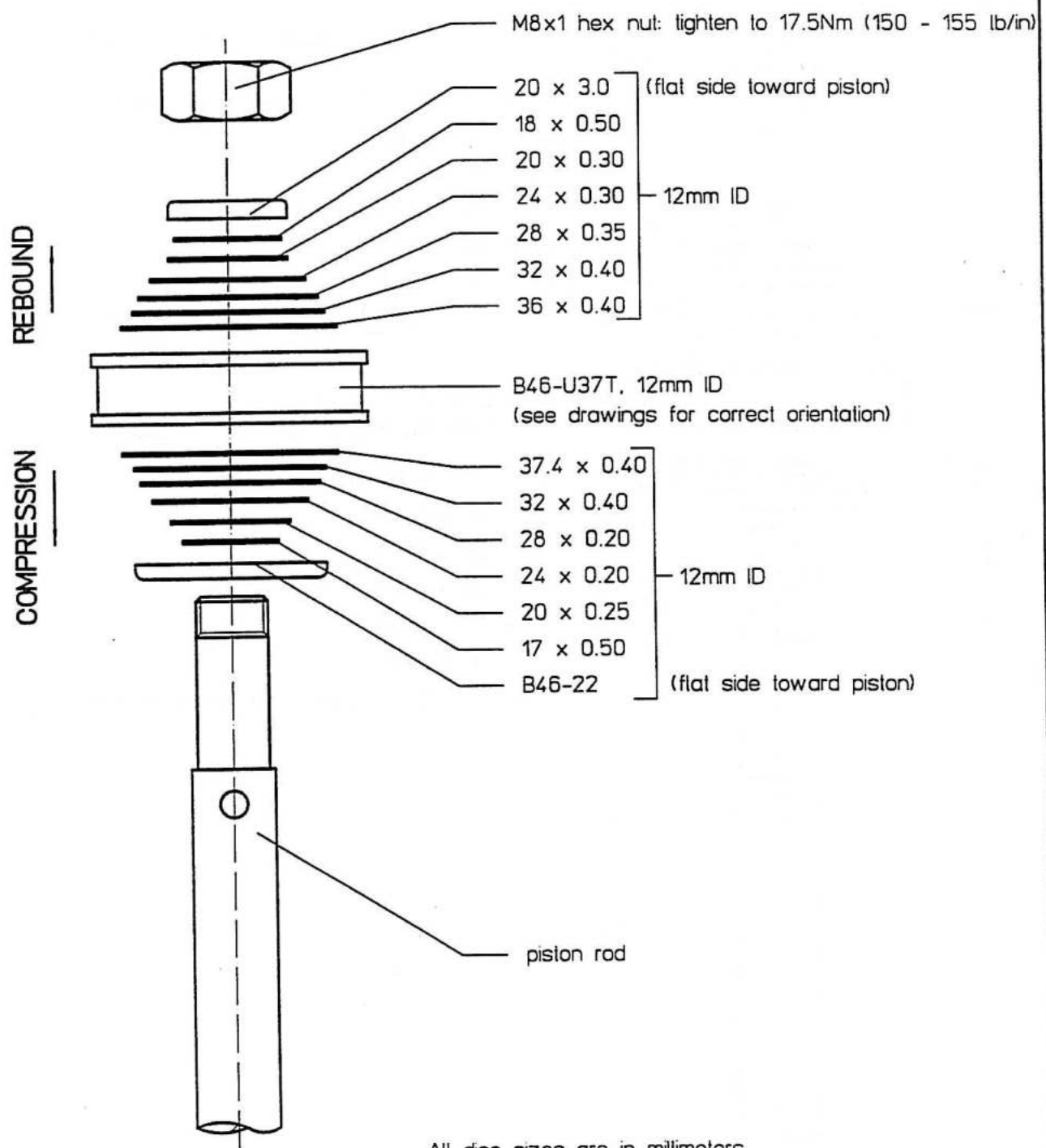

All disc sizes are in millimeters

example:

"32 x 0.30" is 32mm diameter, 0.30mm thick



VALVING: GNA6
760-237 (LINEAR)

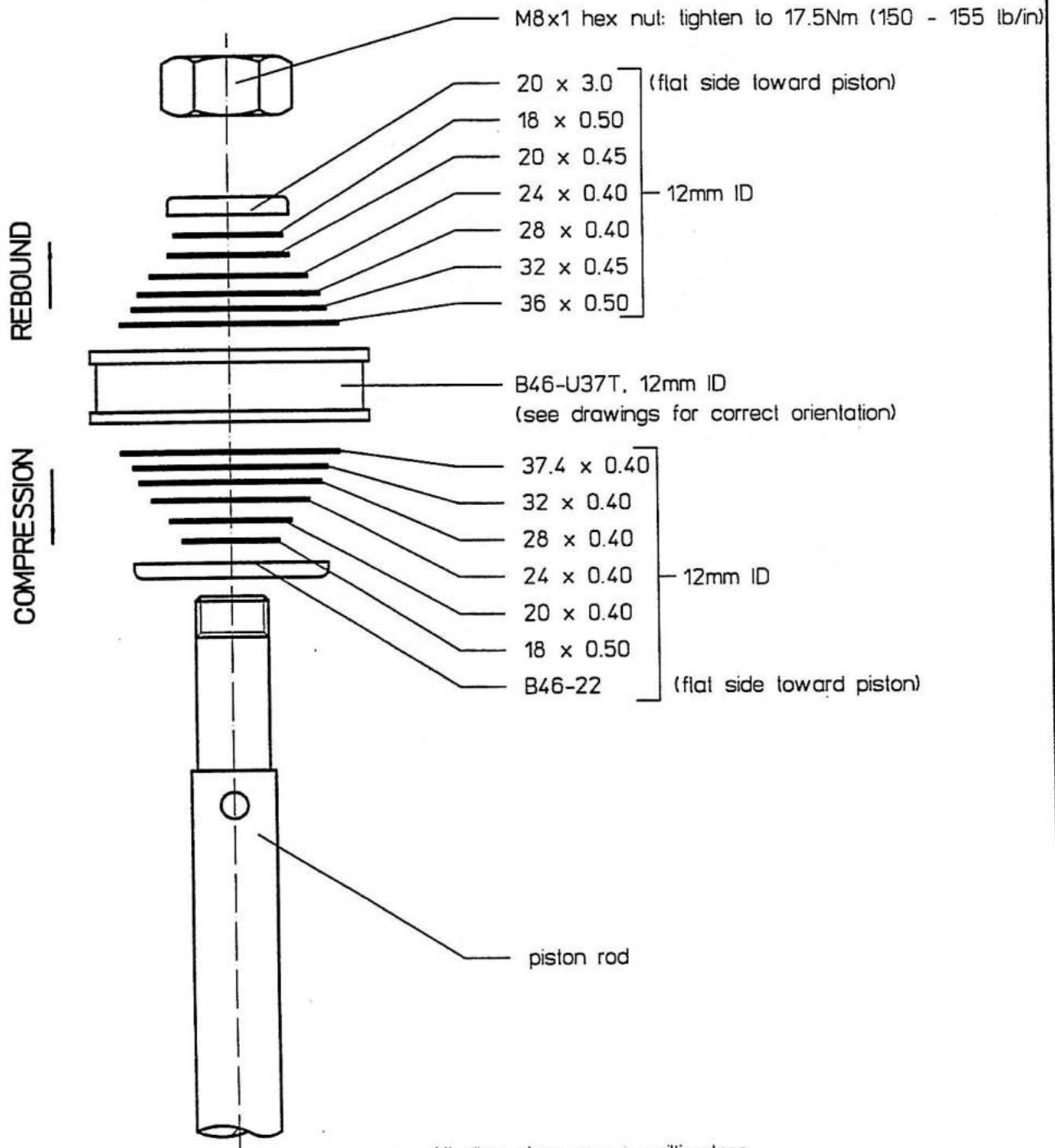

All disc sizes are in millimeters

example:

"32 x 0.30" is 32mm diameter, 0.30mm thick



VALVING: GNA9

398-143 (LINEAR)

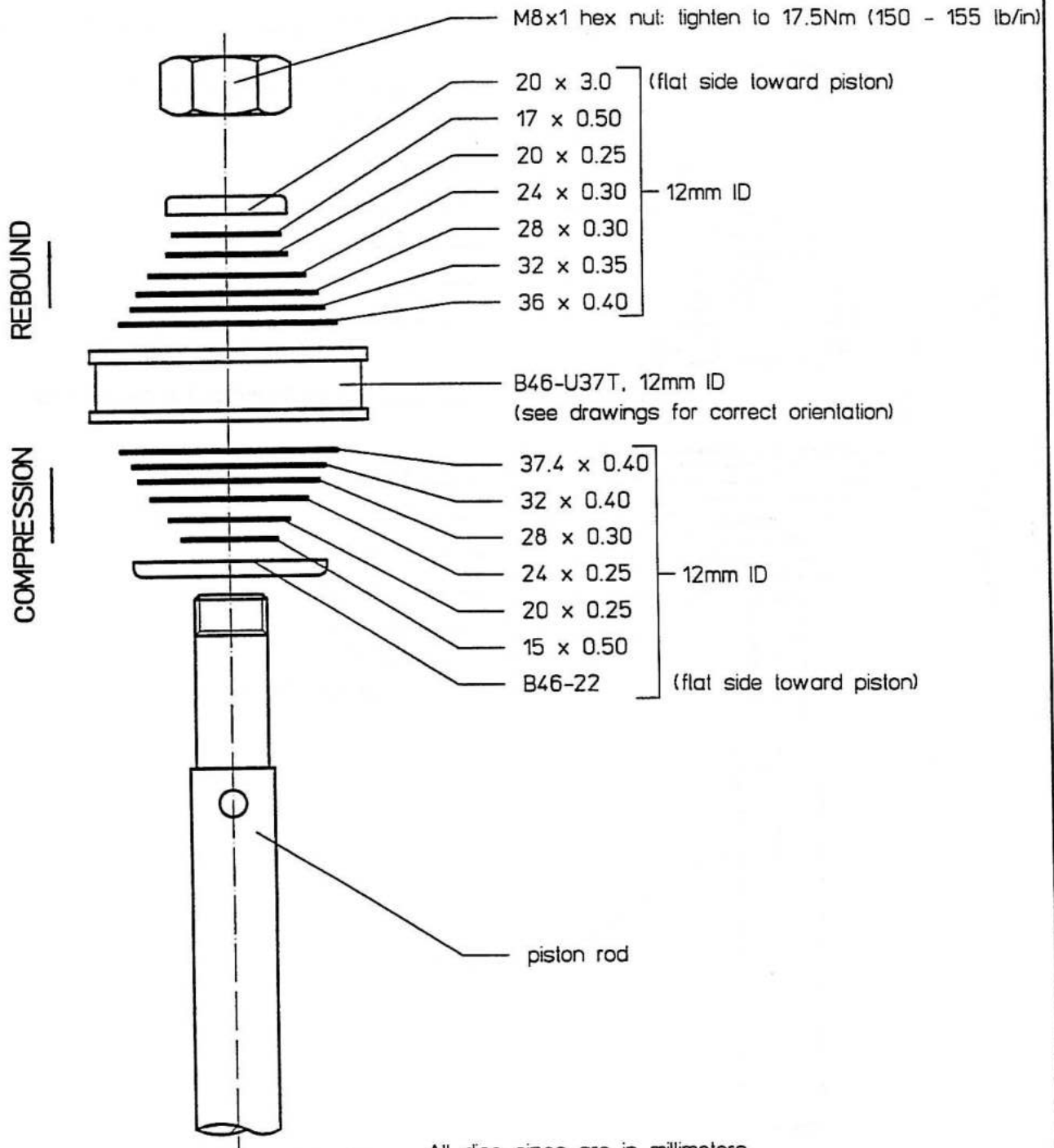

All disc sizes are in millimeters

example:

32 x 0.30 is 32mm diameter, 0.30mm thick



VALVING: _____ (LINEAR)

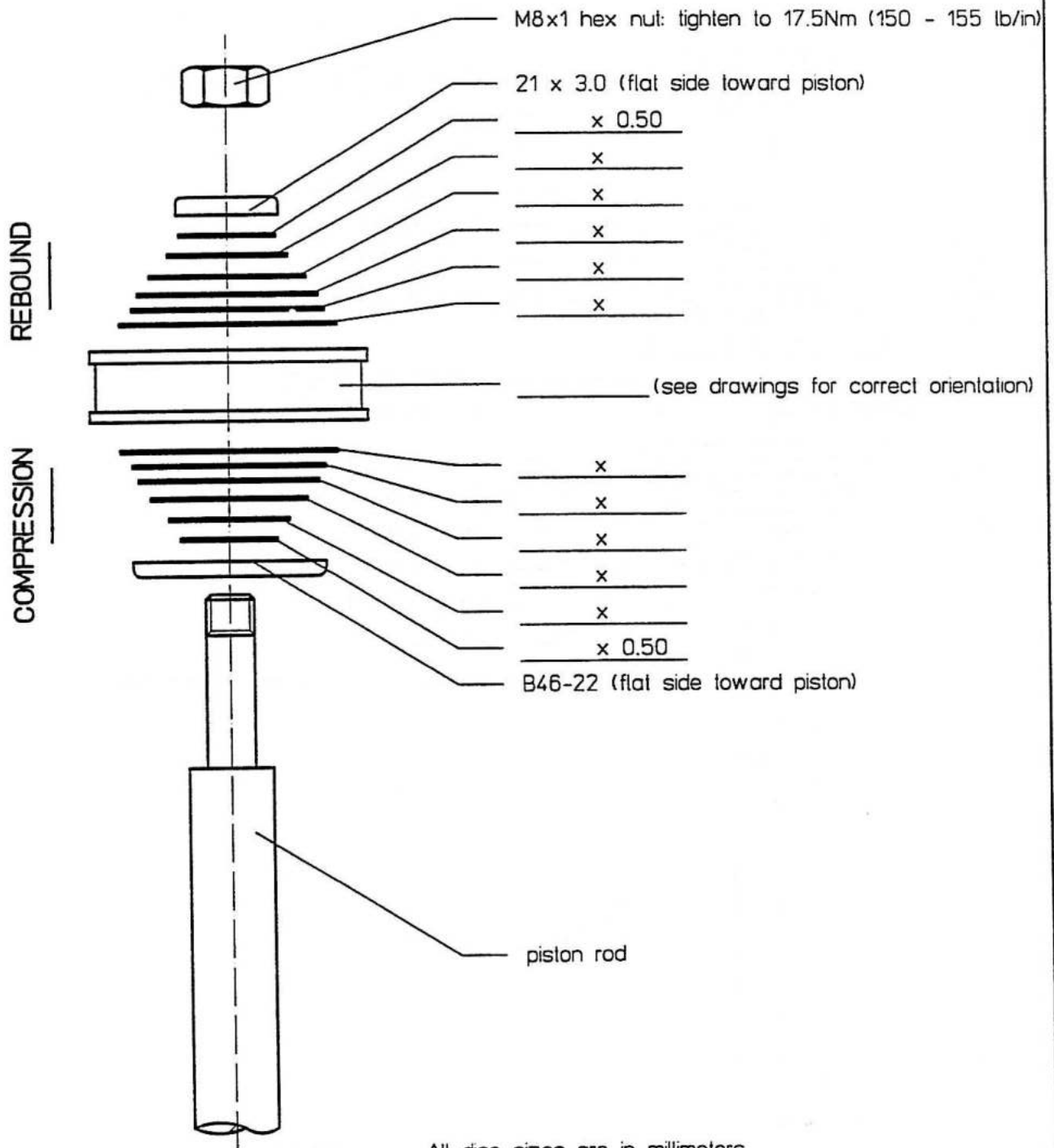

All disc sizes are in millimeters

example:

'32 x 0.30' is 32mm diameter, 0.30mm thick



VALVING: _____ (DIGRESSIVE)

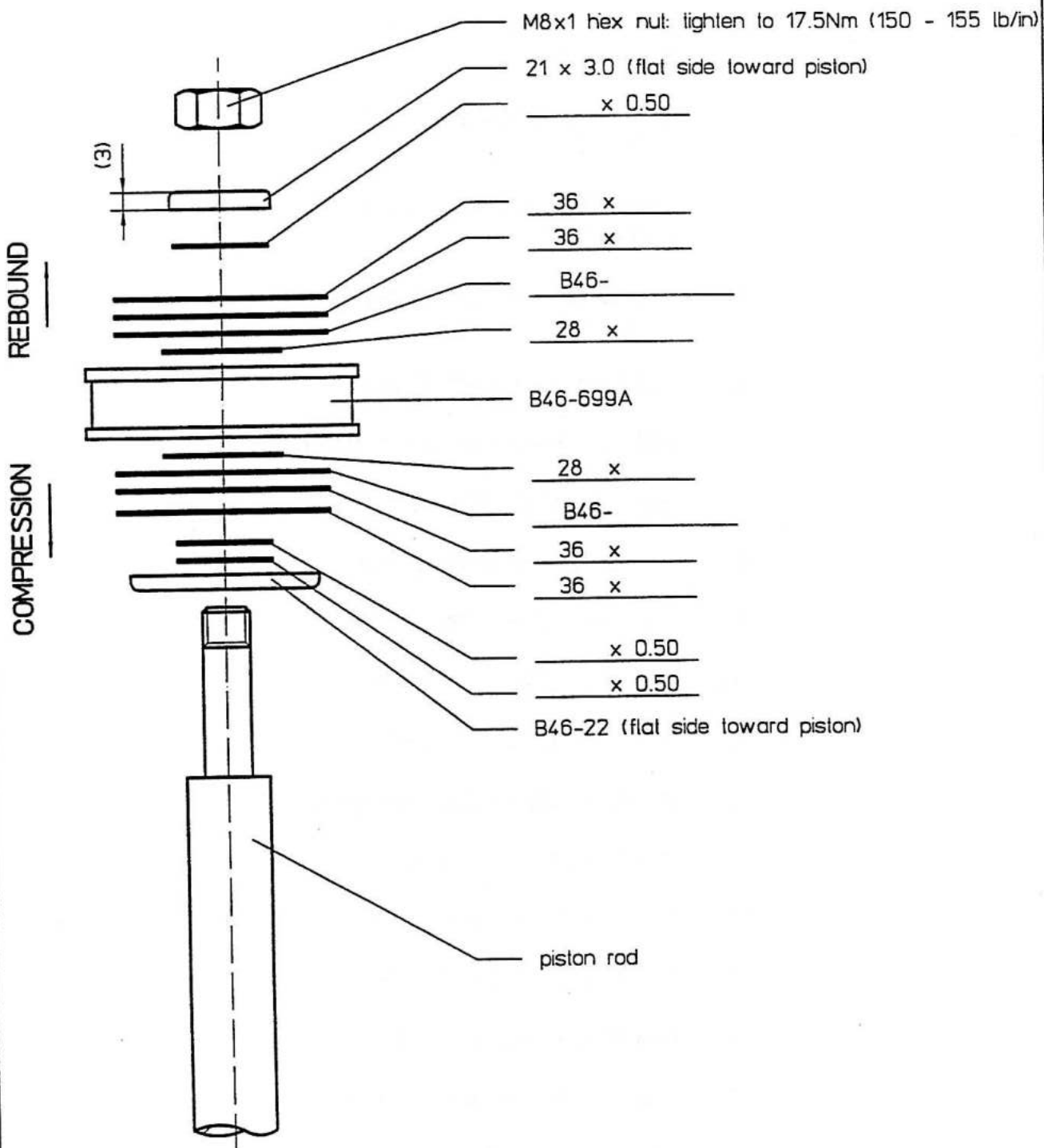

All disc sizes are in millimeters

example:

36 x 0.50 is 36mm diameter, 0.50mm thick



OIL VOLUME FOR MOTORSPORTS SHOCKS

1. B46-0201 - 239 cm^{3**} (5 in.)
(B46-0204)*
2. B46-0202 - 272 cm^{3**} (6 in.)
(B46-0205)*
3. B46-0210 - 305 cm^{3**} (7 in.)
(B46-0211)*
4. B46-0203 - 320 cm^{3**} (8 in.)
(B46-0206)*
5. B46-0209 - 320 cm^{3**} (8 in.)
6. B46-GNTF1-19 - 320 cm^{3**} (8 in.)
7. B46-GNTR2-8 - 320 cm^{3**} (8 in.)
8. B46-0207 - 369 cm^{3**} (9 in.)
9. B46-DTA / LTA5 - 239 cm^{3**} (5 in.)
10. B46-DTA / LTA6 - 272 cm^{3**} (6 in.)
11. B46-DTA / LTA7 - 305 cm^{3**} (7 in.)
12. B46-DTA / LTA8 - 320 cm^{3**} (8 in.)
13. B46-DTA / LTA9 - 369 cm^{3**} (9 in.)
14. B46-ATAD5 - 239 cm^{3**} (5 in.)
15. B46-ATAD7 - 305 cm^{3**} (7 in.)
16. B46-ATAD9 - 369 cm^{3**} (9 in.)
17. B46-60BG8 - 390 cm^{3**} (8 in.)

* Denotes Threaded Body version

** cm³ = cc or ml (fluid measurement)